

The Flock of Birds[®]

POSITION AND ORIENTATION MEASUREMENT SYSTEM

INSTALLATION AND OPERATION GUIDE

Standalone

and

Multiple Transmitter/Multiple Sensor Configurations

January 18, 1999

*Copyright 1996 Ascension Technology Corporation
PO Box 527
Burlington, Vermont 05402
(802) 893-6657*

The Flock of Birds[®]

POSITION AND ORIENTATION MEASUREMENT SYSTEM

INSTALLATION AND OPERATION GUIDE

Standalone

and

Multiple Transmitter/Multiple Sensor Configurations

January 18, 1999

*Copyright 1996 Ascension Technology Corporation
PO Box 527*

Burlington, Vermont 05402
(802) 893-6657

FCC Regulations

Warning: Changes or modifications to this unit not expressly approved by the party responsible for compliance could void the user's authority to operate the equipment.

NOTE: This equipment has been tested and found to comply with the limits for a Class A digital device, pursuant to Part 15 of the FCC Rules. These limits are designed to provide reasonable protection against harmful interference when the equipment is operated in a commercial environment. This equipment generates, uses, and can radiate radio frequency energy and, if not installed and used in accordance with the instruction manual, may cause harmful interference to radio communications. Operation of this equipment in a residential area is likely to cause harmful interference in which case the user will be required to correct the interference at his own expense.

Canadian Regulations

This digital apparatus does not exceed the Class A limits for radio noise emissions from digital apparatus set out in the Radio Interference Regulation of the Canadian Department of Communications.

Le present appareil numerique n'emet pas de bruits radioelectriques depassant les limites applicables aux appareils numeriques de la class A prescrites dans le Reglement sur le brouillage radioelectrique edicte par le ministere des Communications du Canada.

European Regulations

This equipment has been tested and found to conform to the harmonized European Union (CE) standards EN 50081-1, and 50082-1.

TABLE OF CONTENTS

1.0 INTRODUCTION	1
2.0 UNPACKING YOUR SYSTEM	5
2.1 INSTALLATION	6
2.1.1 ELECTRONICS UNIT LOCATION	6
2.1.2 TRANSMITTER LOCATION	6
2.1.3 SENSOR LOCATION	7
2.1.4 POWER SUPPLY LOCATION	7
2.1.5 INTERNAL JUMPERS	7
2.1.6 ADDRESSING MODE CONFIGURATION	10
2.1.7 DIPSWITCH CONFIGURATION	10
2.2 CABLE ATTACHMENT	15
2.2.1 RS-232C CABLE	15
2.2.2 FBB CABLE - Bird to Bird	15
2.2.3 FBB CABLE - Host to Bird	15
2.2.4 SENSOR CABLE	16
2.2.5 TRANSMITTER CABLE	16
2.2.6 CRT SYNC CABLE	16
2.2.7 POWER CABLE	16
2.3 EXTENDED RANGE CONTROLLER/TRANSMITTER OPTION	17
2.3.1 EXTENDED RANGE TRANSMITTER LOCATION	17
2.3.2 TRANSMITTER INSTALLATION	18
2.3.3 ERC LOCATION	18
2.3.4 ERC INTERNAL JUMPERS	19
2.3.5 CONFIGURING THE FLOCK WITH AN ERC	20
2.3.6 ERC TRANSMITTER CABLE	20
2.3.7 ERC POWER SUPPLY VOLTAGE SELECTION	20
2.3.8 ERC POWER SUPPLY CABLE	21
3.0 INCLUDED SOFTWARE	22
4.0 RS232 HOST INTERFACE	23
4.1 RS232 SIGNAL DESCRIPTION	23
4.2 RS232 TRANSMISSION CHARACTERISTICS	24
4.3 RS232 JUMPER CONFIGURATION	25
4.4 RS232 DATA RATES	25

5.0	RUNNING THE FLOCK USING AN RS232 INTERFACE	27
5.1	RS232 COMMANDS	27
5.1.1	RS232 COMMAND SUMMARY	28
5.2	RS232 COMMAND UTILIZATION	29
5.2.1	POWER-UP BEHAVIOR	29
5.2.2	RS232/STANDALONE DEFAULT VALUES	33
5.2.3	RS232/FLOCK MODE DEFAULT VALUES	33
5.3	RS232 RESPONSE FORMAT	34
5.3.1	POSITION/ORIENTATION DATA FORMAT	34
5.4	COMMAND USAGE TABLE	37
6.0	FBB HOST INTERFACE	42
6.1	FBB SIGNAL DESCRIPTION	42
6.1.1	FBB/RS485 TERMINATION	43
6.2	FBB/RS485 HOST TRANSMISSION CHARACTERISTICS	43
6.3	FBB/RS485 JUMPER CONFIGURATION	44
6.4	FBB/RS485 CONFIGURATION	45
6.5	FBB COMMANDS	47
6.5.1	FBB COMMAND SUMMARY	48
6.5.2	FBB COMMAND UTILIZATION	48
6.5.3	FBB BIRD DEFAULT VALUES	50
6.6	FBB RESPONSES	50
6.7	FBB COMMAND REFERENCE	51
	FBB RS232CMD	52
	FBB SEND DATA	53
	FBB SEND STATUS	54
	FBB SEND ERROR CODE	55
7.0	FLOCK OPERATIONAL LIMITATIONS	56
8.0	TEST MODES	57
8.1	FACTORY TEST	57
8.2	BIRD OUTPUT	57
8.3	BIRD ECHO	58
8.4	HOST DATA READ	58
8.5	HOST DATA READ BLOCK	58
8.6	TEST FOR SENSOR	58
8.7	DON'T TEST FOR SENSOR	58
8.8	SET NORMAL ADDRESS MODE	59
8.9	SET EXPANDED ADDRESS MODE	59
8.10	SET SUPER-EXPANDED ADDRESS MODE	59

9.0 RS232 COMMAND REFERENCE	60
ANGLES	61
ANGLE ALIGN1	63
ANGLE ALIGN2	65
BUTTON MODE	67
BUTTON READ	68
CHANGE VALUE	69
EXAMINE VALUE	69
BIRD STATUS	72
SOFTWARE REVISION NUMBER	73
BIRD COMPUTER CRYSTAL SPEED	73
POSITION SCALING	74
FILTER ON/OFF STATUS	75
DC FILTER CONSTANT TABLE ALPHA_MIN	76
BIRD MEASUREMENT RATE COUNT	77
BIRD MEASUREMENT RATE	78
DISABLE/ENABLE DATA READY OUTPUT	79
SET DATA READY CHARACTER	79
ERROR CODE	79
ERROR DETECT MASK	80
DC FILTER TABLE Vm	80
DC FILTER CONSTANT TABLE ALPHA_MAX	81
SUDDEN OUTPUT CHANGE LOCK	82
SYSTEM MODEL IDENTIFICATION	83
EXPANDED ERROR CODE	83
XYZ REFERENCE FRAME	84
TRANSMITTER OPERATION MODE	84
FBB ADDRESSING MODE	85
FILTER LINE FREQUENCY	85
FBB ADDRESS	85
CHANGE/EXAMINE HEMISPHERE	86
CHANGE/EXAMINE ANGLE ALIGN2	86
CHANGE/EXAMINE REFERENCE FRAME2	87
BIRD SERIAL NUMBER	87
SENSOR SERIAL NUMBER	87
XMTR SERIAL NUMBER	87
FBB HOST RESPONSE DELAY	88
GROUP MODE	88
FLOCK SYSTEM STATUS	89
FBB AUTO-CONFIGURATION	90
FACTORY TEST	94
FBB RESET	95
HEMISPHERE	96

MATRIX	98
NEXT TRANSMITTER	100
POINT	102
POSITION	103
POSITION/ANGLES	104
POSITION/MATRIX	105
POSITION/QUATERNION	106
QUATERNION	107
REFERENCE FRAME1	108
REFERENCE FRAME2	110
REPORT RATE	111
RS232 TO FBB	112
RUN	114
SLEEP	115
STREAM	116
SYNC	117
XOFF	120
XON	121
10.0 ERROR MESSAGES	122
10.1 ERROR MESSAGE DETAILS	124
11.0 GETTING IN AND OUT OF TROUBLE	129
APPENDIX I - NOMENCLATURE	132
APPENDIX II - OPTIONAL POWER SUPPLY SPECIFICATIONS	133
APPENDIX III - BIRD SPECIFICATIONS	134
APPENDIX IV - JUMPER LOCATIONS ON THE BIRDS CIRCUIT BOARD	135
APPENDIX V - APPLICATION NOTES	137
Compute The Coordinates of a Stylus Tip	137
Convert Bird Outputs to a Graphics Modeling Matrix	138
Flock Stand-alone Power Supply	140
CRT Sync Pulse Electrical Requirements	141
Using Multiple Host RS485 Interfaces	142
Configuring The Bird For Minimum Lag	144

USER MANUAL REVISIONS

<u>Manual Date</u>	<u>Changes</u>
August 13, 1991	Initial release for the one transmitter/multiple sensor configurations.
August 21, 1991	Jumper diagrams added, Jumper tables corrected, Examine/Change Vm added.
October 4, 1991	FBB SEND STATUS command corrected. Included software Section 3.0 changed to reflect latest user software release. Error messages expanded. New dipswitch assignment and values for FBB baud rates. Must have rev 3.16 or greater PROM software in the Flock to utilize these new baud rates.
November 4, 1991	FBB Next Transmitter command added. Examine/Change Alpha_max and Sudden Output Lock added. Clear to send communications protocol implemented on RS485 interface.
February 28, 1992	Commands added: Next Transmitter and RS232 TO FBB. Error codes expanded. FBB Next Transmitter deleted. FBB run-time commands can now be greater than one byte long. Clear to send (CTS) protocol eliminated from the RS485 interface.
March 30, 1992	Revised Next Transmitter Command. Added Next Master Command. Added Host Read Data and Host Read Block Data Tests. Updated User Error Messages. Alpha_min and Alpha_max examine/change values are now a table of values instead of a single value. Definitions of Masters and Slaves changed. Corrected jumper assignments for SYNC input. Must have rev 3.28 or greater PROM software to utilize these new commands.
May 5, 1992	Test mode dipswitch settings corrected. Examine/Change value data formats clarified. Bird measurement rate constant changed from 0.9 to 0.3. FBB termination description changed.
June 1, 1992	Quaternion output formats added. Host sync command expanded to reduce output lag. Filter defaults changed. Save configuration command deleted. Bit assignments in the system status word have changed. You must have rev 3.29 or greater PROM software to utilize the new commands.
June 15, 1992	Added requirement to connect jumper 14 on first Flock unit on the bus. Default bus termination jumper setting descriptions for jumpers 10, 14, 16 changed to agree with hardware.
July 5, 1992	Filter defaults changed. Error messages updated.
October 12, 1992	Added extended addressing mode. Added tests #29 & #31. Updated baud rate definitions for extended addressing mode. Added group mode. Stream mode is now allowed on the FBB. You must have rev 3.33 or greater PROM software to utilize the new commands.

November 9, 1992 FBB ARM examine value command corrected.

USER MANUAL REVISIONS

<u>Manual Date</u>	<u>Changes</u>
December 11, 1992	Added Examine Extended Error Code information and Application Note #5 on using multiple RS485 interfaces.
January 26, 1993	Conversion factor for vertical retrace speed in SYNC command reduced by a factor of two starting with rev 3.39 PROM software. Application note #1 revised.
March 8, 1993	FBB/RS485 interface command structure has changed with rev 3.41 PROM. References to extended addressing changed to Expanded Addressing to avoid confusion with the extended range transmitter. Expanded error code bit assignments corrected. Examine Flock system status added.
May 25, 1993	Examine/Change XYZ REFERENCE FRAME command added. Must have rev 3.45 or greater PROM software to utilize this new command.
July 5, 1993	RS232 TO FBB command corrected for Expanded Addressing mode.
September 2, 1993	Dipswitch setting to enable Expanded Addressing changed from test #31 to test #27 starting with rev 3.47 PROM software.
February 8, 1994	Vm table values changed to agree with rev 3.52 and greater PROMs. Misc. text changes made.
July 18, 1994	Various text improvements.
October 17, 1994	RS232 TO FBB command corrected for Expanded Address mode. STATUS B12 corrected. JPR 13 changed to JPR 17 and jumper function changed starting with PCB rev 6B. Starting with rev 3.57 PROM software the light now blinks twice on powerup if in Expanded Address mode.
January 31, 1995	Delays now required before and after AUTO-CONFIG. Misc. text improvements.
June 22, 1996	Examine/Change Bird Measurement Rate added. AUTO-CONFIG command description expanded. Added Reference Frame1/Frame2, Angle Align1/Align2 and test for sensor. You need at least rev 3.63 PROM software for these new commands.
December 8, 1997	Added the ability to have up to 126 FBB devices. Added FBB Reset command. Added the following Change/Examine commands: Addressing Mode, Line Frequency, FBB Address, Hemisphere, Angle Align2, Reference Frame2, Serial Number. You need to have at least EPROM software rev 3.67 for these new commands.
February 18, 1998	Changed the word receivers to sensors. Added how to change the angles from Hex to degrees. Corrected various bugs/misprints in the text.
January 18, 1999	Added the Sensor Serial Number and Transmitter Serial Number commands. You

need to have at least EPROM software rev 3.71 for these new commands.

1.0 INTRODUCTION

The Flock of Birds (FOB) is a six degree-of-freedom measuring device that can be configured to simultaneously track the position and orientation of up to thirty sensors by a transmitter. Each sensor is capable of making from 20 to 144 measurements per second of its position and orientation when the sensor is located within ± 4 feet of its transmitter. An optional extended range transmitter increases this operating range to ± 8 feet. The FOB determines position and orientation by transmitting a pulsed DC magnetic field that is simultaneously measured by all sensors in the Flock. From the measured magnetic field characteristics, each sensor independently computes its position and orientation and makes this information available to your host computer.

An FOB consists of one or more Ascension Bird electronic units or extended range transmitter controllers interconnected via a Fast Bird Bus (FBB). To increase the Flock size, just plug an additional Bird unit into the FBB for each additional transmitter or sensor required. Because each Bird attached to the bus has its own independent computer, the FOB can simultaneously track each sensor, providing up to 144 measurements per second from each.

Each Bird unit in the Flock contains two independent serial interfaces. The first interface is for communications between your host computer and the FOBs. You may configure this interface as either a full duplex RS-232C interface or a half duplex RS422/485 interface. The second interface is a dedicated RS485 interface for communications between the Flock members. The user and intra-flock RS422/485 buses are generically called the Fast Bird Bus. Your host computer may utilize either a single or multiple RS232/422/485 interfaces to command and receive data from all Bird units. The host can send commands and receive data from any individual Bird unit because each Bird unit is assigned a unique address on the FBB via back-panel dipswitches.

The FOBs can be configured to suit the needs of many different applications: from a standalone unit consisting of a single transmitter and sensor to more complex configurations consisting of various combinations of transmitters and sensors. Figures 1, 2, 3 and 4 show a one transmitter/multiple sensor configuration for simultaneously tracking many sensors with one transmitter. In Figure 1 the user's host computer uses the FBB for communication. In Figure 2 it utilizes a single RS-232C port. In Figure 3 it utilizes multiple RS-232C ports. Figure 4 shows an extended range controller and transmitter attached to the FBB to allow the sensors to operate up to 8 feet away from the transmitter. In these figures, the Master Bird is the Flock Bird that is controlling and coordinating the operation of all other Slave Birds - Slaves because they can only speak

when spoken to by the Master or host. The user's host computer communicates with the Master to start and stop the Flock and perform other major Flock control functions. There can only be one Master running on the FBB at a time. The Master Bird may have its own transmitter but this is not a requirement. The Flock can also run using a transmitter attached to a Slave. If the Slave unit has a transmitter, the user's host computer may tell the Master to turn on a given Slave's transmitter.

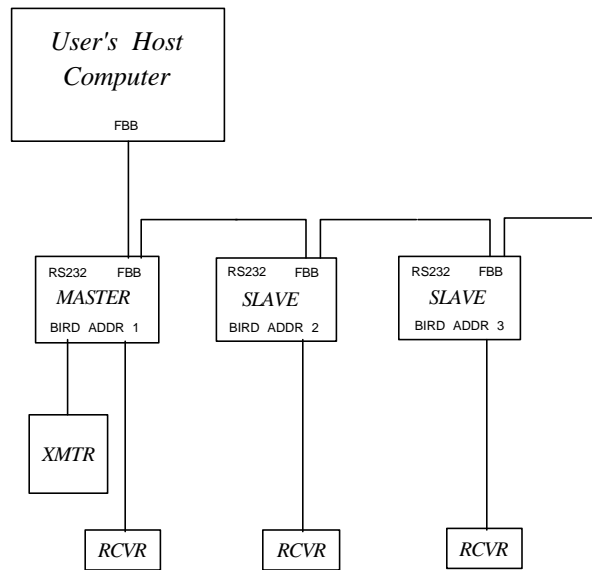

Figure 1. FOBs With A Single FBB Interface To Host Computer

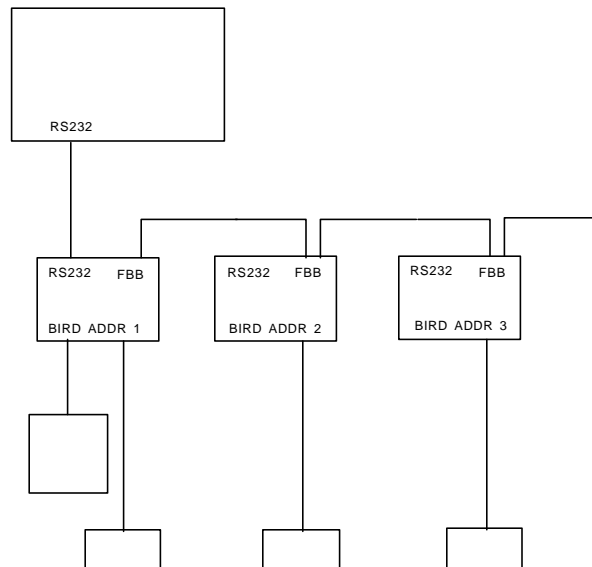

Figure 2. FOBs With Single RS232 Interface To Host Computer

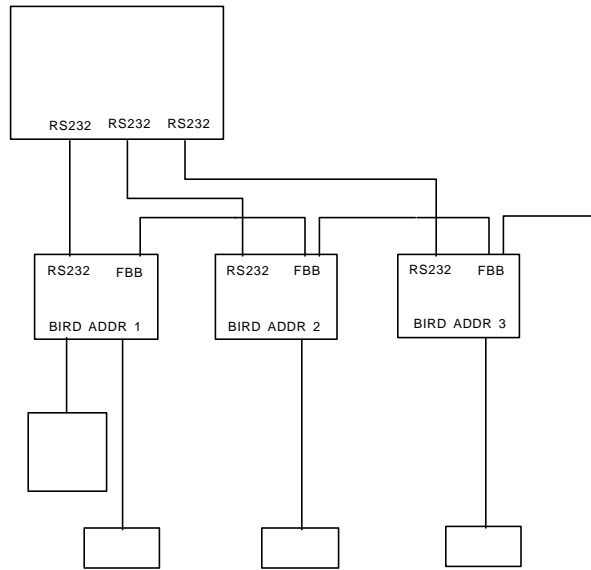

Figure 3. FOBs With Individual RS-232C Interfaces To Host Computer

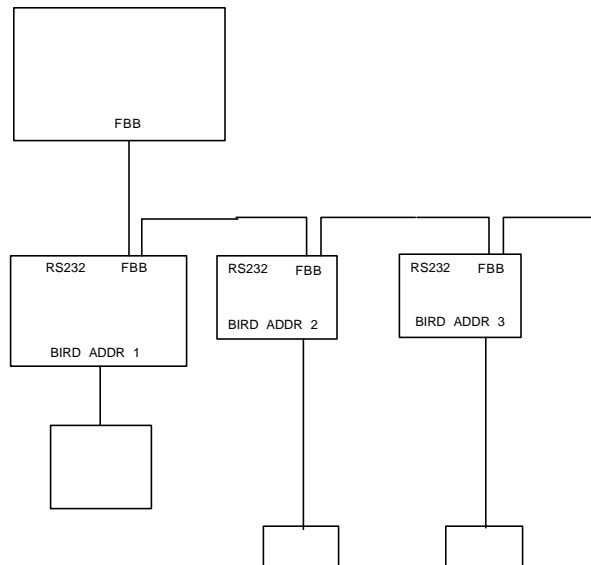

Figure 4. FOBs With Extended Range Controller/Transmitter Using A Single FBB Interface

2.0 UNPACKING YOUR SYSTEM

The Flock of Birds are shipped to you in one or more boxes. Each box containing our standard range Flock configuration contains:

1. One electronics unit.
2. One Standard Range Transmitter. Only one of the boxes will contain a transmitter when you order a one transmitter/multiple sensor configuration.
3. One sensor housed in a small cube or a mouse with cable attached.
4. One CRT synchronization pickup/cable. One per system.
5. One Fast Bird Bus inter-unit bus cable if you ordered more than one Flock Bird, modular connectors both ends.
6. One Fast Bird Bus cable, Bird to host cable, modular connector one end with 9 pin D male connector on other end. One per system if you specified your Flock to be set up for an RS485 interface.
7. One optional USA/European external power supply with a USA wall cord.
8. One bag of four spare jumper blocks.
9. Two 3 1/2 inch DOS-formatted diskettes per system.
10. One Installation and Operation Guide. One per system.

The optional Extended Range Transmitter is shipped in two additional boxes:

1. The Extended Range Transmitter
2. Then Extended Range Controller with one FBB inter-unit bus cable and an internal USA/European power supply with a USA wall cord.

If there are any discrepancies, or your shipment is damaged, call Ascension Technology at (802) 893-6657 between the hours of 9 AM and 5 PM Eastern Standard Time.

2.1 INSTALLATION

2.1.1 ELECTRONICS UNIT LOCATION. Generally, the electronics unit can be mounted anywhere. However, it is best if the unit is not located on top of or under other electronic equipment that is not shielded. When locating the electronics unit, you must ensure that the ventilating slots on the sides of the enclosure are not obstructed. The plastic cases are designed so that multiple units can be stacked on top of each other.

Because it is possible, through movement of the sensor cable, to pull the electronics unit off of its perch, you should use some sort of secondary restraint, such as taping the sensor cable to the desk, near where it connects to the unit.

2.1.2 TRANSMITTER LOCATION. The transmitter should be mounted on a non-metallic surface such as wood or plastic, using non-metallic bolts or 300 series stainless steel bolts. It also may be mounted on the top front edge of the electronics unit. If you are going to mount the transmitter upside down, note that the two mounting holes are not strong enough to support the weight of the transmitter. Instead you should use hardware or grooves to capture the flanges along both sides of the transmitter in addition to bolting through the two mounting holes. Do not mount the transmitter on the floor (concrete included), ceiling or walls because these all contain metal or may have large metal objects directly on their opposite side.

Because the transmitter generates magnetic fields, it may interfere with your computer's display, causing image bending, jitter or color distortion. With an unshielded commercial CRT-type display, the transmitter usually must be at least 12 inches away. With a shielded CRT, the transmitter can be closer.

CAUTION

**THE TRANSMITTER AND SENSOR ARE DELICATE
INSTRUMENTS. DO NOT DROP THEM.**

2.1.3 SENSOR LOCATION. The sensor should also be mounted on a non-metallic surface such as wood or plastic, using non-metallic bolts or 300 series stainless steel bolts. It should not be located near power cords, power supplies, or other low-frequency current-generating devices. Their emanations will be picked up by the sensor and converted into noise on the output position and orientation measurements. The sensor will pick up noise when it is operated near a CRT-type display. The amount of noise will vary depending on the operating frequency of the CRT and the amount of shielding built into the CRT. To minimize noise picked up from the CRT, use the CRT SYNC command in conjunction with the CRT synchronization pickup cable provided with your Flock unit.

2.1.4 POWER SUPPLY LOCATION. The optional power supply should be located where there is adequate ventilation for cooling. Do not locate the supply within two feet of the sensor. Locate the supply at least one foot away from the electronics unit.

2.1.5 INTERNAL JUMPERS. Inside each electronics unit is a set of jumper blocks that must be set to conform to the type of interface you are using. If you have notified Ascension of your interface before the unit was shipped, then the jumpers have been preset for you. If not, the jumpers in each unit are set at the factory for the RS-232C interface using the flock's baud rate generator. To change the jumpers, you must open up each electronics unit.

D A N G E R

**THERE ARE STATIC SENSITIVE CIRCUIT
COMPONENTS ON THE PCB. GROUND YOURSELF
BEFORE TOUCHING THE PCB TO DISSIPATE ANY
STATIC CHARGE THAT MAY HAVE BUILT UP ON
YOUR CLOTHING.**

1. OPEN THE ELECTRONICS ENCLOSURE:

- a. Unplug all cables attached to the unit.
- b. Turn the unit upside down.
- c. Loosen, but do not remove, the four screws found in each of the black support legs. These screws secure the top half of the enclosure.
- d. Turn the unit over so it is standing on its legs and lift the top cover off vertically. Do not try to remove the front and rear back panels.

2. LOCATE THE JUMPERS:

Table 1 contains a list of all jumpers in the electronics unit. Refer to Section 4 if using an RS232 interface, Section 6 if using a single RS485/422 interface, or Application Note #5 if using multiple RS485/422 interfaces to determine what jumpers to insert or remove. To locate the jumpers refer to the printed circuit card drawings in Appendix IV. The jumper blocks can be removed and inserted vertically with a strong set of fingers.

3. REPLACE THE TOP OF THE ENCLOSURE:

- a. Slide the top over the front and rear panels. There is a left and right side to the top. One side has male grooves, the other female.
- b. Invert the electronics unit.
- c. Tighten the four hold down screws. Do not over tighten.
- d. You are done.

TABLE 1 JUMPER FUNCTIONS FOR THE BIRD

<u>Jumper</u>	<u>Function</u>
3	1 - 2 connected, FBB/RS485 host control 1 - 2 not connected, RS232 host control *
9	1 - 2 connected, TTL Sync Signal enable 2 - 3 connected, CRT Sync Signal enabled *
10	1 - 2 connected, FBB CTS terminated 1 - 2 not connected, FBB CTS not terminated *
12	1 - 2 connected, FBB Receive Data enabled 2 - 3 connected, RS232 Receive Data enabled *
13 ¹	1 - 2 connected, FBB CTS enabled 2 - 3 connected, RS232 CTS enabled *
14	1 - 2 connected, FBB BIRD DATA terminated 1 - 2 not connected, FBB BIRD DATA not terminated *
15	1 - 2 connected, TTL single Sync input 2 - 3 connected, factory-supplied CRT Sync input cable*
16	1 - 2 connected, FBB HOST DATA terminated 1 - 2 not connected, FBB HOST DATA not terminated *
17 ¹	1 - 2 connected, FBB reset is enabled 1 - 2 not connected, FBB reset is not enabled *

Notes:

* indicates factory default setting

1 if the circuit board is Rev 6B or greater, three pin JPR 13 will not be present. In its place is a two pin JPR 17 which has a different function.

2.1.6 ADDRESSING MODE CONFIGURATION. The Bird can be operated in three addressing modes: 1) Normal Addressing mode, 2) Expanded Addressing mode, and 3) Super-Expanded Addressing mode.

Normal Addressing mode is used when you have up to 14 Bird units in your Flock. This mode is the default mode set at the factory. Normal Addressing mode may be permanently changed or set by setting the dipswitches to test number #29 (see Section 8.0 for details).

Expanded Addressing mode is used when you have more than 14 Bird units in your Flock. In this mode all transmitters must be at addresses 1 to 14 and the sensors are at addresses 1 to 30. In Expanded Address mode the sensors must be further than 10 inches from the transmitter for the position/orientation information to be correct (or 32 inches for an Extended Range Transmitter). If the sensor is closer than this limit, position and orientation outputs will be zeroed. For example, in MATRIX output mode, all nine output words would be zero. Expanded Addressing mode may be permanently changed or set by setting the dipswitches to test number #27 (see Section 8.0 for details).

Super-Expanded Addressing mode is used when you have more than 30 Bird units in your Flock. In this mode all transmitters must be at addresses 1 to 14 and the sensors are at addresses 1 to 126. In Super-Expanded Address mode the sensors must be further than 10 inches from the transmitter for the position/orientation information to be correct (or 32 inches for an Extended Range Transmitter). If the sensor is closer than this limit, position and orientation outputs will be zeroed. Super-Expanded Addressing mode may be permanently changed or set by setting the dipswitches to test number #31 (see Section 8.0 for details).

2.1.7 DIPSWITCH CONFIGURATION. On the back panel of each Bird unit there is a dipswitch that must be set to select the baud rate, unit address and other functions. Whenever you change the dipswitch settings, you must toggle The Bird's FLY/STDBY switch to STDBY and then back to FLY for the new settings to be recognized by the system. The switch assignments are as follows in Figure 5 for Normal Addressing mode and Figure 6 for Expanded Addressing mode. Super-Expanded Addressing mode only has the one default baud rate of 115.2K.

Dipswitch 8

For the FOB to be in an operational mode (FLY), where it can output position and orientation, dipswitch 8 must be set to OFF. When dipswitch 8 is set to ON, the system enters TEST mode where it performs the functions specified by the test number set in switches 4, 5, 6, 7. Refer to Section 8.0 for details on each test.

Dipswitches 4, 5, 6, 7 - Normal Addressing Mode (default)

When in Normal Address mode (Up to 14 Bird units on the FBB i.e. 1 ERC plus up to 13 sensors.), each Bird unit on the FBB is assigned a unique address via dipswitches 4, 5, 6, 7. For example, the ERC might have its address dipswitch set to 1 = 0001 = off, off, off, on. The first Bird sensor card in the chassis would then have its addresses set to 2 = 0010. The addresses do not have to be in order, but you cannot skip an address, no addresses can be set to zero, there can be no repeat addresses, and there can be no address = 15 (the Broadcast Address).

Dipswitches 3, 4, 5, 6, 7 - Expanded Addressing Mode

When in Expanded Address mode (up to 30 Bird units on the FBB), each Bird unit on the FBB is assigned a unique address via switches 3, 4, 5, 6, 7. For example, the ERC might have its address dipswitch set to 1 = 00001 = off, off, off, off, on. The first Bird sensor card in the chassis would then have its addresses set to 2 = 00010. The addresses do not have to be in order, but you cannot skip an address, no addresses can be set to zero, there can be no repeat addresses, and there can be no address = 31 (the Broadcast Address). All ERT addresses must be located at addresses 1 to 14.

Dipswitches 1, 2, 3, 4, 5, 6, 7 - Super-Expanded Addressing Mode

When in Super-Expanded Address mode (up to 126 Bird units on the FBB), each Bird unit on the FBB is assigned a unique address via switches 1, 2, 3, 4, 5, 6, 7. For example, the ERC might have its address dipswitch set to 1 = 1000000 = on, off, off, off, off, off, off. The first Bird sensor card in the chassis would then have its addresses set to 2 = 0100000. The addresses do not have to be in order, but you cannot skip an address, no addresses can be set to zero, there can be no repeat addresses, and there can be no address = 127 (the Broadcast Address). All ERT addresses must be located at addresses 1 to 14.

Dipswitches 1, 2, 3 - Normal Address mode (default) baud rate

Dipswitches 1, 2 - Expanded Address mode baud rate

These switches select the desired baud rate.

Note: The FBB/RS485 baud rates listed are nominal values. Your host computer can use a baud rate up to 2.5% larger or up to 5.5% less than the listed values. For example, with The Bird's baud set at 260,417, your host computer can use a baud rate of 250,000 and communicate without error.

Note: The Super-Expanded Address mode has only one baud rate of 115.2K.

Figure 4. Dipswitch Settings - Normal Address Mode

```

      Dipswitch position
1     2     3     4     5     6     7     8
+-----+-----+-----+-----+
*
*           /)))))) In Fly Mode, FBB address (0-30)
*           *
*           *           Dipswitch #
*           *           3   4   5   6   7   FBB Addr
*           *           off off off off off   0
*           *           off off off off on    1
*           *
*           *           .
*           *           .
*           *           .
*           *           on  on  on  on off    30
*           *           on  on  on  on on    invalid
*
*           .)))))) In Test Mode, test number
*           *
*           *           Dipswitch #
*           *           4   5   6   7   Test #
*           *           off off off off    1
*           *           off off off on    3
*           *
*           *           .
*           *           .
*           *           .
*           *           on  on  on  on    31
*
/))))))))) Baud rate when RS232 interface selected
*           *
*           *           Dipswitch #
*           *           1   2   Baud
*           *           off off    9600
*           *           off on    19200
*           *           on  off    38400
*           *           on  on    115200
*
.))))))))) Baud rate when FBB(RS485) interface selected.
Host CPU baud may vary +2.5/-5.5% from the
values listed below. Baud is a function of
The Bird's crystal (MHz).

           Dipswitch #
           1   2   Baud(32MHz)   Baud(40 MHz)
           off off    250000    250000
           on  off    333333    500000
    
```

DIP SETTING: OFF = switch UP
 ON = switch DOWN

Figure 5. Dipswitch Settings - Expanded Address Mode

```

      Dipswitch position
      1  2  3  4  5  6  7  8
      |-----|-----|-----|-----|-----|-----|-----|-----|
      |-----|-----|-----|-----|-----|-----|-----|-----|
      *
      /)))))) In Fly Mode, FBB address (0-126)
      *
      *           Dipswitch #
      *           1  2  3  4  5  6  7  FBB Addr
      *           |-----|-----|-----|-----|-----|-----|-----|
      *           off off off off off off off      0
      *           on  off off off off off off      1
      *           off on  off off off off off      2
      *           on  on  off off off off off      3
      *
      *
      *
      *           .
      *           .
      *           .
      *           off on  on  on  on  on  on      126
      *           on  on  on  on  on  on  on      invalid
      *
      .)))))) In Test Mode, test number
      *
      *           Dipswitch #
      *           4  5  6  7  Test #
      *           |-----|-----|-----|-----|-----|
      *           off off off off      1
      *           off off off on      3
      *
      *
      *
      *           .
      *           .
      *           .
      *           on  on  on  on      31
  
```

Note: The addresses run backwards from Normal or Expanded Addressing modes (i.e. for Normal and Expanded Addressing modes address = 1 would have pin 7 down, but for Super-Expanded Addressing mode pin 1 is down).

Note: There are no Baud rate dipswitches. Baud rate defaults to 115.2K for RS232.

Note: Baud rate when FBB(RS485) interface selected. Host CPU baud may vary +2.5/-5.5% from the values listed below. Baud is a function of The Bird's crystal (MHz).

<u>Baud(32MHz)</u>	<u>Baud(40MHz)</u>
333333	500000

DIP SETTING: OFF = switch UP
 ON = switch DOWN

Figure 6. Dipswitch Settings - Super-Expanded Address Mode

2.2 CABLE ATTACHMENT

CAUTION

DISCONNECT THE AC LINE CORD FROM THE POWER SUPPLY BEFORE CONNECTING OR DISCONNECTING ANY CABLES!

Note: If you are using a power source other than the optional power supply, you may not have access to the AC line cord. In that case, disconnect the DC power plug at The Bird. Important note: switching The Bird to STDBY does NOT turn the power off!

2.2.1 RS-232C CABLE. If your host interface to The Bird is via RS-232C then prepare the cable(s) according to the specification in Section 4.1 or as defined in the user software diskette file RS232.TXT, and attach it to the 9-pin female connector labeled 'RS-232' on the rear panel of the appropriate electronics unit. If you are using a single RS232 port to talk to all Birds in the Flock, then attach the RS232 cable to the Master Bird (see Section 4.4). If you are using a separate RS232 port for each Bird then connect the RS232 cables to every member of the Flock. Verify that you have not plugged the RS232 cable into the XMTR connector.

2.2.2 FBB CABLE - Bird to Bird. If you are using one or more RS232 or RS485 ports to communicate with the Flock then use the supplied FBB cables to interconnect The Birds for FOB operation in the daisy-chained fashion as indicated in Figure 1, 2, 3 or 4. The cables are plugged into either of the 8-pin modular connectors on the rear panel, labeled 'FBB'. If you are using multiple RS485 ports to communicate with the Flock then you will have to modify The Bird to Bird FBB CABLE per Application Note #5.

2.2.3 FBB CABLE - Host to Bird. If your host interface to The Bird is via a single FBB/RS485 interface then attach the supplied cable to either of the 8-pin modular connectors labeled 'FBB' on the rear panel of the 'Master Bird' electronics unit. The connector on the other end of this cable is a 9 pin D male connector wired per the diagram in the user diskette file "RS485.TXT". If your host computer's RS485 interface wiring or connector differs from the supplied cable then you will have to fabricate an appropriate mating connector. If you want to use multiple RS485 interfaces to gather

data from the Flock, refer to Application Note #5.

2.2.4 SENSOR CABLE. Attach the sensor to the 15-pin connector labeled 'RECEIVER' on the rear panel of the electronics unit.

2.2.5 TRANSMITTER CABLE. If you have the standard range transmitter, attach it to the 9-pin connector labeled 'XMTR' on the front panel of The Bird electronics unit. Verify that you have not plugged the transmitter cable into the RS232 connector.

2.2.6 CRT SYNC CABLE. If you are going to use the sensor within a few feet of a magnetically deflected CRT display (a normal picture tube-type raster-scan monitor), you may need the CRT sync cable to reduce CRT noise picked up by The Bird's sensor. The CRT sync cable contains a CRT sync pickup housing with a velcro pad for attachment to the outside of your CRT. The end of the cable is plugged into the connector labeled 'SYNC' on the rear panel of the Master Bird. Be certain that the connector is fully inserted into the SYNC connector inside The Bird's enclosure and not merely making contact with the back panel. The connector must go partially into the back panel to be seated correctly. For proper operation, it is vital that the sync pickup be correctly positioned on the CRT cabinet. Follow the instructions in Section 9.0 for the SYNC command to properly position the pickup. Peel the protective paper from the tape on the velcro attachment and fasten the pickup to the CRT's housing at the predetermined location. Note: once you have enabled CRT sync by setting the SYNC command equal to either CRTSYNCtype 1 or 2, The Bird will stop running if the pickup falls off the CRT.

2.2.7 POWER CABLE. When using the optional power supply, attach the power plug to the 9-pin connector labeled 'POWER' on the rear of the electronics unit and set the FLY/STDBY switch to STDBY before plugging in the AC line cord. If you are using your own power supply, it must conform to the voltage, amperage, and wiring requirements listed in Appendices II and III.

CAUTION**SCREW IN ALL CABLE CONNECTORS OTHERWISE
ERRATIC SYSTEM BEHAVIOR MAY RESULT**

2.3 EXTENDED RANGE CONTROLLER/TRANSMITTER OPTION

If you did not purchase the Extended Range Transmitter option, then you do not need to read this section. The Flock of Birds with the Extended Range Controller (ERC) and Extended Range Transmitter (ERT) option is a six degree of freedom measuring device that can be configured to simultaneously track the position and orientation of up to 125 sensors with up to four ERTs when using a single ERC. Each sensor is capable of making from 10 to 144 measurements/second of its position and orientation when the sensor is located within ± 8 feet of the ERT.

The ERT option has been designed for simplicity of use and versatility. One ERT mounted on a pedestal in the center of a room generates sufficient signal to allow a user, equipped with one or more motion-tracking sensors to walk about a 16 x 16 foot room. With four ERTs in an array, he can walk about a 24 x 24 foot room. No matter how many ERTs are included in a configuration, the Flock will continue to maintain its high measurement rate.

2.3.1 EXTENDED RANGE TRANSMITTER LOCATION. The most critical item in installing an ERT is selecting a location for placement of the transmitter. A poor location will result in degraded measurement accuracy by The Flock of Birds.

When large metal objects are near the transmitter and sensor(s) they will affect the accuracy of the position and angle measurements. A large metal object is considered to be near when the distance from the transmitter to sensor is the same as the distance from the transmitter or sensor to the large metal object. Large metal objects include metal desks, bookcases, files, and the floor, ceiling and walls. In non-wood commercial buildings the floor and possibly the ceiling are constructed of concrete that contains a mesh of reinforcing steel bars. Walls might be constructed of cinder blocks or plaster

board. Plaster board walls, however, usually have internal steel supports spaced every sixteen inches. Even if the wall has no metal in it there may be a large metal object directly on the other side, such as someone's desk. Usually the largest source of error is due to the floor. If you are going to use the sensors at a distance of eight feet from the ERT then the ERT and sensors should be eight feet away from the floor, ceiling, walls, or other large metal objects.

The only way to evaluate the building effects is to install the ERT and determine if the accuracy is satisfactory for your application. You can evaluate the accuracy degradation simply by taping one sensor to a cardboard box or yard stick or some other method of holding the sensor at a fixed distance above the floor. As you move the sensor farther away from the ERT in the X direction record the sensor's Z position output. If the floor is not causing a large error then the Z position output will remain relatively constant as you move away from the transmitter.

The ideal location for the ERT is in an all wood building or in a large room with a stage above the floor for mounting the transmitter and using the sensors.

Because the ERT generates magnetic fields, it may interfere with your computer's display, causing image bending, jitter or color distortion. With an unshielded commercial CRT-type display, the ERT usually must be located at least four feet away.

2.3.2 TRANSMITTER INSTALLATION. Usually the ERT is mounted on a 3 or 4 foot high wood pedestal in the center of the motion capture space or mounted overhead or under the floor of a wood stage. Because the transmitter is very heavy (50 lbs), fragile, and subject to performance degradation by nearby metal, the method that you use to support the transmitter must be strong and non-metallic. Small amounts of metal in the mount such as steel bolts are acceptable. Supporting the transmitter on a steel or aluminum framework is not acceptable. We recommend wood, structural fiberglass, or laminated phenolic for mounting materials. Two bolt holes in the bottom of the transmitter have been provided for maintaining the alignment of the transmitter to your support. These bolts are not strong enough to support the weight of the transmitter and therefore must not be used to support or 'tie down' the transmitter to your mount. The alignment bolt threads inside the bottom of the transmitter are 10-24. Thread engagement will occur 1 3/4 inches into the base. You should screw the bolt in an additional 1/2 inch for full engagement but no more.

The cable from the transmitter to the ERC contains high voltages and currents and therefore must be protected so that the cable will not be stepped on. Run the cable through the ceiling, or under the floor or if the cable is on the floor use a rigid cable protector that can be walked on such as 'Cordgard- Electrical Cord Ducting' available through Arrow Electronics and other electrical and electronic distributors. Putting the cable under a piece of rug will not provide protection, it will only create a fire hazard.

2.3.3 ERC LOCATION. The ERC can be located either near the ERT or near The Bird electronics unit, however, **DO NOT STACK THE ERC ON TOP OF THE BIRD ELECTRONICS UNIT.** This will generate noise in the position and orientation measurements.

2.3.4 ERC INTERNAL JUMPERS. If you must change the internal jumpers note that there are dangerous voltages inside the enclosure. Turning the on/off switch to off will not remove the dangerous voltages. You must unplug the power cord before removing the enclosure top. Refer to Section 4 if using an RS232 interface or Section 6 if using an RS485/422 interface. To locate the jumpers refer to the printed circuit card drawings in Appendix IV.

DANGER HIGH VOLTAGE

Remove the power cord from the ERC before opening to eliminate the dangerous high voltages inside

<u>Jumper</u>	<u>Function</u>
1, 2	do not exist
3	1 - 2 connected when using RS485 host control 1 - 2 not connected when using RS232 host control *
4 - 9	do not exist
10	1 - 2 connected, BIRD BUS CTS terminated * 1 - 2 not connected, BIRD BUS CTS not terminated
11	1 - 2 connected, FBB reset is enabled

	1 - 2 not connected, FBB reset is not enabled *
12	1 - 2 connected, RS485 host receive data enabled 2 - 3 connected, RS232 host receive data enabled *
13	does not exist
14	1 - 2 connected, BIRD BUS data terminated * 1 - 2 not connected, BIRD BUS data not terminated
15	does not exist
16	1 - 2 connected, RS485 HOST BUS data terminated * 1 - 2 not connected, RS485 HOST BUS data not terminated

Notes: * indicates factory default setting

2.3.5 CONFIGURING THE FLOCK WITH AN ERC. In general, the ERC is treated as just another Flock Bird that must be attached to the FBB and must have a bus address of 1 to 14 assigned via the dipswitches on the ERC's front panel. As shipped from the factory the ERC address is set to 1 (i.e. the default bus Master).

The ERC, in combination with the rest of the Flock Birds, can interface to the user's host computer via one or more RS232 or RS485 interfaces. When using a single interface, the host interface must be attached to The Bird unit you specify as the bus Master. When using individual RS232 interfaces to each Bird you can operate the ERC without an RS232 interface as long as the ERC is selected to be a Slave. In this configuration you would send the Next Transmitter command to the bus Master to tell the Master the address of the ERC.

If you are going to use an external Sync signal to synchronize the Flock to minimize CRT noise, the ERC must be selected as a Slave since it does not have a Sync input. The Sync signals can only be utilized by the current bus Master.

2.3.6 ERC TRANSMITTER CABLE. The ERC can control up to two ERTs or with the expansion option installed, four ERTs. The front panel connectors are labeled 'XMTR' 1, 2, (3, 4). If you ordered one ERT then all other connectors are capped. **DO NOT REMOVE THESE CAP(S).** They protect the user from exposure to high voltages.

The ERC/ERT will not work if the cap is removed. Plug an ERT cable connector into the corresponding front panel connector and screw in the connector. Erratic system operation will result if the connector is not screwed in place.

D A N G E R H I G H V O L T A G E

**Do not remove the protective caps from the unused
ERC connectors**

2.3.7 ERC POWER SUPPLY VOLTAGE SELECTION. The ERC contains a built in universal AC power supply that will work in either North America by selecting 110 volts or in most of Europe by selecting 220 volts. If you are not sure what the correct voltage is in your country ask someone who knows. The system will be damaged and the warranty voided if you do not select the correct voltage. The voltage selector is located below the power switch/power cord on the back panel. Insert a screw driver into the selector and rotate until the appropriate voltage is aligned with the arrow.

2.3.8 ERC POWER SUPPLY CABLE. The ERC is shipped with a North American 110 volt power cord. If your country uses 220 volts, your local hardware/electrical store can supply you with the correct cable. Before installing the cable, switch the ON/OFF switch located directly above the cable connector of OFF. The switch is OFF when you can see 'O' on the side edge of the switch. The switch is 'ON' when you can see 'I' on the other side edge of the switch. Insert the power cable connector into the back panel. Push hard with a slight wiggle of the connector to completely engage the connector.

3.0 INCLUDED SOFTWARE

Two 3.5 inch DOS formatted diskettes are included with your unit. These diskettes contain source code for Bird interface software written in Basic, C, and assembly language. These programs let you send commands to The Bird from a menu and read output data on the screen. They run on any IBM PC compatible computer. In addition, the C program can be run on many of the UNIX platforms.

The diskettes contain five directories: FLOCK232, FLOCK485, DUAL485, DIGITIZE and NOISE. Dir FLOCK232 contains files written in assembly language, Basic, and C that allow you to run the Flock of Birds using an RS-232C interface. This directory contains the following three executable files generated from the source files using polled interrupts: ABIRD.EXE is written in assembly language, BBIRD.EXE in BASIC and CBIRD.EXE in C.

Dir FLOCK485 contains a PC compatible assembly language program to operate the Flock of Birds using a single RS-485 interface via a QUATECH interface card.

Dir DUAL485 contains 'C' code for running the Flock with multiple RS-485 interfaces.

Dir DIGITIZE contains a program written in Basic that computes the coordinates of a stylus attached to the sensor.

Dir NOISE contains a program written in Basic that determines the best operating speed to minimize noise in the measurements.

Check the diskettes for a file called READ.ME, it contains additional information about the software included on the diskettes. Additional programming notes to the 'C' user can be found in files CNOTES.TXT and UNIX.TXT. Instruction files for running the programs are called OPERATEa.TXT, OPERATEb.TXT, and OPERATEc.TXT and are located in the ASM, BASIC, and C subdirectories. Feel free to incorporate any of this software into your own application or product.

4.0 RS232 HOST INTERFACE

If your host computer is using a FBB/RS485 interface to the Flock then you do not need to read Section 4.x. You should, however, read Section 5.x.

4.1 RS232 SIGNAL DESCRIPTION

The RS-232C interface conforms to the Electronic Industries Association (EIA) specifications for data communications. A pinout and signal description of the RS-232C interface is found below. Note that The Bird requires connections only to pins 2, 3 and 5 of the 9-pin interface connector. The file named RS232.TXT on The Bird software diskette contains additional information about the RS-232 interface to several different computers.

The Bird's 9-pin RS-232C connector is arranged as follows:

<u>PIN</u>	<u>RS232 SIGNAL¹</u>	<u>DIRECTION</u>
1	Carrier Detect	Bird to host
2	Receive Data	Bird to host
3	Transmit Data	host to Bird
4	Data Terminal Rdy	Host to Bird
5	Signal Ground	Bird to host
6	Data Set Ready	Bird to host
7	Request to Send	host to Bird
8	Clear to Send	Bird to host
9	Ring Indicator	No Connect

Notes:

- 1) These are the EIA RS232 signals names. The Bird is configured as Data Communication equipment (DCE) and therefore Transmit Data is an input and Receive Data is an output.

RS-232C signal description:

<u>SIGNAL</u>	<u>DESCRIPTION</u>
Carrier Detect	Indicates The Bird is FLYing when high ¹
Receive Data	Serial data output from The Bird to the host
Transmit Data	Serial data output from the host to The Bird
Data Terminal Rdy	Host data flow control, suspends all data transmission from The Bird when low (internally pulled high to +12V).
Signal Ground	Signal reference
Data Set Ready	Indicates The Bird is FLYing when high ¹
Request to Send	Holds The Bird in standby when high, Bird Flies when low
Clear to Send	Indicates The Bird is FLYing when high ¹
Ring Indicator	Signal is not used

Notes:

- 1) These signals are high when The Bird is NOT in the reset (standby) condition. There are two ways by which The Bird can be placed in the reset condition: when the front panel switch is in Standby, or when the RS232 Request to Send signal is high.

4.2 RS232 TRANSMISSION CHARACTERISTICS

The host computer must be configured for the following data characteristics:

Baud Rate	2400 - 115,200 (as set by Bird dipswitch.)
Number of data bits	8
Number of start bits	1

Number of stop bits	1
Parity	none
Full duplex	

4.3 RS232 JUMPER CONFIGURATION

For host communications to the Flock of Birds using RS232 set the following jumpers. See Table 1 in Section 2.1.5 for a description of these jumpers.

<u>Jumper</u>	<u>Configuration</u>
JPR 3	pins 1-2 not connected
JPR 12	pins 1-2 not connected, pins 2-3 connected
JPR 13	if present, pins 1-2 not connected, pins 2-3 connected
JPR 10	pins 1-2 connected on first and last Bird on the FBB
JPR 14	pins 1-2 connected on first and last Bird on the FBB
JPR 16	pins 1-2 connected on first and last Bird on the FBB
JPR 17	if present, pins 1-2 not connected.

For host communications to the ERC using RS232 set the following jumpers. See Section 2.2.4 for a description of these jumpers.

<u>Jumper</u>	<u>Configuration</u>
JPR 3	pins 1-2 no connection
JPR 12	pins 2-3 connected

4.4 RS232 DATA RATES

As shown in Figures 2 or 3, when your host computer is using an RS-232 interface to communicate with the Flock of Birds, it can utilize either one serial port connected to the Master to communicate with all Birds, or a separate RS232 port for each Bird in the Flock. Using a single RS232 port to talk to all Birds has the advantage of requiring less host hardware; it has the disadvantage of limiting the number of measurement per second that your host can read from each Bird. Table 2 below shows the maximum data record output rate that can be obtained when using a separate RS232 interface to each

Bird (the first table entry) or a single RS232 interface for all Birds. The rate that your host computer is able to obtain will be less than or equal to these table values depending on the time lags imposed by your host computer's operating system, for example, a UNIX operating system will slow the I/O down to such an extent that you may only be able to achieve one third of the maximum rates listed.

Table 3.
Maximum RS232 Data Record Output Rate

DATA OUTPUT FORMAT (Records Output / Sec / Bird)				
Number of Sensors	Baud Rate	Position	Position/Angles	Position/Matrix
1	19.2K	203	113	66
1 Master or 1 Slave	38.4K	309	206	120
	115.2K	515	412	219
2	19.2K	102	57	33
1 Master	38.4K	154	103	60
1 Slave	115.2K	257	206	108
3	19.2K	68	38	22
1 Master	38.4K	103	68	40
2 Slaves	115.2K	171	137	72
4	19.2K	51	28	16
1 Master	38.4K	77	51	30
3 Slaves	115.2K	128	103	54
5	19.2K	40	22	13
1 Master	38.4K	61	41	24
4 Slaves	115.2K	103	82	43
6	19.2K	34	19	11
1 Master	38.4K	51	34	20
5 Slaves	115.2K	85	68	36
7	19.2K	29	16	9
1 Master	38.4K	44	29	17
6 Slaves	115.2K	73	58	30
8	19.2K	25	14	8
1 Master	38.4K	38	25	15
7 Slaves	115.2K	64	51	27
10	19.2K	20	11	6
1 Master	38.4K	30	20	12
9 Slaves	115.2K	51	41	21

Notes: 1) The rates that are greater than 100 (The Bird's default measurement rate) are not meant to imply that each Bird is making this many measurements. Rather it indicates that you can request and receive data over the RS232 port at a rate greater than The Bird is making its measurements. When you request data at a rate greater than the measurement rate you will get duplicate data records. Rates less than 100 do not mean The Bird is making measurements this slowly. The Birds are always making 100 measurements per second per sensor independent of how many sensors are in a Flock. When you request data at a rate less than the measurement rate you will lose data records.

2) Rates for UNIX platforms will be much less than these table values.

3) Writes to the screen or disk will reduce these table values.

5.0 RUNNING THE FLOCK USING AN RS232 INTERFACE

The Birds in the Flock talk to each other via the FBB interconnect cable. To enable The Birds to exchange data among themselves, each Bird is assigned a unique FBB address via the configuration dipswitch, see Section 2.1.7. If your host has an individual RS232 communications channel to each Bird, the RS232 commands you send to The Birds do not have a Bird address associated with the command. If you utilize a single RS232 interface to talk to all of The Birds then the commands you send must contain the address of The Bird that you want to respond (see the RS232 TO FBB command).

5.1 RS232 COMMANDS

Each RS232 command consists of a single command byte followed by N command data bytes, where N depends upon the command. A command is an 8 bit value which the host transmits to The Bird using the format shown below.

The RS232 command format is as follows:

	MS BIT									LS BIT
	Stop	7	6	5	4	3	2	1	0	Start
RS232										
Command	1	BC7	BC6	BC5	BC4	BC3	BC2	BC1	BC0	0

where, BC7-BC0 is the 8 bit command value (see RS232 Command Reference) and the MS BIT (Stop = 1) and LS BIT (Start = 0) refers to the bit values that the UART in your computer's RS232 port automatically inserts into the serial data stream as it leaves the computer.

The RS232 command data format is as follows:

	MS BIT									LS BIT
	Stop	7	6	5	4	3	2	1	0	Start
RS232										
Data	1	BD7	BD6	BD5	BD4	BD3	BD6	BD1	BD0	0

where, BD7-BD0 is the 8 bit data value associated with a given command.

If you are going to use a single RS232 port to talk to all of The Birds in a Flock instead of

multiple RS232 ports then you must preface each RS232 command with the RS232 TO FBB command.

5.1.1 RS232 COMMAND SUMMARY. The following summarizes the action of each command. The details of command usage are presented in Section 5.7.

<u>Command Name</u>	<u>Description</u>
ANGLES	Data record contains 3 rotation angles.
ANGLE ALIGN	Aligns Bird to reference direction.
BUTTON MODE	Sets how the mouse button will be output.
BUTTON READ	Reads the value of the mouse button pushed.
CHANGE VALUE	Changes the value of a selected Bird system parameter.
EXAMINE VALUE	Reads and examines a selected Bird system parameter.
FACTORY TEST	Enables factory test mode.
FBB RESET	Resets all of the Slaves through the FBB.
HEMISPHERE	Tells Bird desired hemisphere of operation.
MATRIX	Data record contains 9-element rotation matrix.
NEXT TRANSMITTER	Turns on the next transmitter in the Flock.
POINT	One data record is output for each B command from the selected Flock unit. If GROUP mode is enabled, one record is output from all running Flock units.
POSITION	Data record contains X, Y, Z position of sensor.
POSITION/ANGLES	Data record contains POSITION and ANGLES.
POSITION/MATRIX	Data record contains POSITION and MATRIX.

POSITION/QUATERNION Data record contains POSITION and QUATERNION.

QUATERNION Data record contains QUATERNIONS.

REFERENCE FRAME Defines new measurement reference frame.

REPORT RATE Number of data records/second output in STREAM mode.

RS232 TO FBB Use one RS232 interface connection to talk to all Birds.

RUN Turns transmitter ON and starts running after SLEEP.

SLEEP Turns transmitter OFF and suspends system operation.

STREAM Data records are transmitted continuously from the selected Flock unit. If GROUP mode is enabled then data records are output continuously from all running Flock units.

SYNC Synchronizes data output to a CRT or your host computer.

XON Resumes data transmission that has been halted with XOFF.

XOFF Halts data transmission from The Bird.

5.2 RS232 COMMAND UTILIZATION

5.2.1 POWER-UP BEHAVIOR. The FLY/STDBY switch on the front panel is NOT an on/off power switch. There is always power applied to the electronics unit as long as the power supply is plugged in. When the switch is set to FLY, and if the host is not asserting the RTS (Bird RESET) signal on the RS232 interface, then The Bird will perform its power up functions. During power up, The Bird reads the dipswitch and internal jumpers to determine its mode of operation. If the RS232 RTS signal wire is not attached to The Bird, The Bird will perform its power up function as soon as the FLY/STDBY switch is switched to FLY. The initial behavior of The Bird after power up depends on the mode of operation (STANDALONE or FOB) selected by the dipswitches.

If The Bird is configured for Standalone operation (one Bird unit with a transmitter and sensor and with its address set = 0 via the dipswitches), then the front panel light will blink 5 times if in Normal Address mode, 2 times if in Expanded Address mode, or 1 time if in Super-Expanded Address mode and then turn on steady. At this time, the transmitter and sensor will begin operating, and

the unit is ready to accept host commands. If during power up, the electronics unit does not detect the presence of a transmitter and sensor, the front panel light will blink the corresponding error code (refer to Section 10.0). When the switch is set to STDBY, the light goes out, the transmitter and sensor are shut off, and the unit does not respond to host computer commands.

If configured for FOB operation (several Bird units interconnected by the FBB with their individual addresses set = 1 through 126 via the dipswitches), then the front panel light will blink 5 times if in Normal Address mode, 2 times if in Expanded Address mode, or 1 time if in Super-Expanded Address mode and then go off. The host computer must then send the Master an AUTO-CONFIG command. On receipt of this command, the front panel lights on all units will turn on. There will be no blinking if operating correctly. If there is a blinking refer to Section 10.0 for the error codes. When configured for FOB Operation, The Bird will not detect if a transmitter and sensor are present, since they are not required of all Flock members.

The host may then tell The Bird what type of data to send when a data request is issued. The desired type of data is indicated by sending one of the following data record commands: ANGLES, MATRIX, POSITION, QUATERNION, POSITION/ANGLES, POSITION/MATRIX, or POSITION/QUATERNION. These commands do not cause The Bird to transmit data to the host. For the host to receive data, it must issue a data request. Use the POINT data request each time you want one data record or use the STREAM data request to initiate a continuous flow of data records from The Bird. If you want to reduce the rate at which data STREAMs from The Bird, use the REPORT RATE command. All commands can be issued in any order and at any time to change The Bird's output characteristics.

The following is a hypothetical command sequence, issued after power-up, which illustrates the use of some of the commands.

For a standalone configuration:

<u>COMMAND</u>	<u>ACTION</u>
ANGLES	Output records will contain angles only.
POINT	Bird outputs ANGLES data record.

STREAM	ANGLE data records start streaming from Bird and will not stop until the mode is changed to POINT.
POINT	An ANGLE data record is output and the streaming is stopped.

For a one transmitter/two sensor Flock configuration using individual RS232 ports to each Flock unit. In this example the Master has one transmitter and one sensor and the Slave has the other sensor. All commands to the Master are send over the Master's RS232 port and all commands to the Slave are sent over the Slave's RS232 port.

<u>COMMAND</u>	<u>ACTION</u>
POSITION/MATRIX	Sent to the Slave to select position and matrix for output.
POSITION/MATRIX	Sent to the Master to select position and matrix for output.
CHANGE VALUE FBB AUTO- CONFIGURATION 2 Flock units	Sent to the Master to start the Flock running.
POINT	Sent to the Master to get one POSITION/MATRIX data record.
POINT	Sent to the Slave to get one POSITION/MATRIX data record.

For a one transmitter/two sensor Flock configuration with a single RS232 port attached to the Master. This one port will send commands and sensor data from both the Master and Slave. In this example the Master, at FBB address = 1, has one transmitter and one sensor and the Slave, at FBB address = 2, has the other sensor.

<u>COMMAND</u>	<u>ACTION</u>
RS232 TO FBB with FBB addr = 1	Lets the Master know that the next command goes to the Flock unit at addr = 1.
POSITION/MATRIX	Master's output format will be position and matrix.
RS232 TO FBB with FBB addr = 2	Lets the Master know that the next command goes to the Flock unit at addr = 2.
POSITION/MATRIX	Slave's output format will be position and matrix.

RS232 TO FBB with FBB addr = 1	Lets the Master know that the next command goes to the Flock unit at addr = 1.
-----------------------------------	--

COMMANDACTION

CHANGE VALUE FBB AUTO- CONFIGURATION 2 Flock units	Sent to the Master to start the Flock running.
---	--

RS232 TO FBB with FBB addr = 1	Lets the Master know that the next command goes to the Flock unit at addr = 1.
-----------------------------------	--

POINT	One POSITION/MATRIX data record returned from the Master.
-------	---

RS232 TO FBB with FBB addr = 2	Lets the Master know that the next command goes to the Flock unit at addr = 2.
-----------------------------------	--

POINT	One POSITION/MATRIX data record returned from the Slave.
-------	--

The next configuration consists of an ERC configured as the Master and twelve Slave sensors with individual RS232 ports to each unit. All commands to the Master are send over the Master's RS232 port and all commands to the Slaves are sent over the Slave's individual RS232 ports.

COMMANDACTION

POSITION/MATRIX	Sent to each Slave to select position and matrix for output.
-----------------	--

CHANGE VALUE FBB AUTO- CONFIGURATION 13 Flock units	Sent to the Master to start the Flock running.
--	--

POINT	Sent to each Slave to get their POSITION/MATRIX data.
-------	---

5.2.2 RS232/STANDALONE DEFAULT VALUES. Upon power-up, The Standalone Bird (address = 0) is in the following default mode:

1. POINT mode
2. POSITION/ANGLE outputs selected
3. XON
4. RUN activated
5. REPORT RATE = Q (maximum)
6. ANGLE ALIGN sines/cosines set for alignment angles of zero
7. REFERENCE FRAME sines/cosines set for reference angles of zero
8. BUTTON MODE = 0 for no button value output
9. FACTORY TEST commands not active
10. Maximum range scaling = 36 inches
11. Filter on/off status = AC WIDE notch on, DC on, AC NARROW notch off
12. Filter constants ALPHA_MIN Table values = 0.02
13. Filter constants ALPHA_MAX Table values = 0.9
14. Sudden output change lock = 0 allows sudden changes to be output
15. System measurement rate = 100 measurements/sec
16. SYNC = 0 for no synchronization

5.2.3 RS232/FLOCK MODE DEFAULT VALUES. Upon power-up, The RS232 controlled Flock Bird (address = 1 through 126) is in the following default mode:

1. POINT mode
2. POSITION/ANGLE outputs selected
3. XON
4. RUN deactivated
6. ANGLE ALIGN sines/cosines set for alignment angles of zero
7. REFERENCE FRAME sines/cosines set for reference angles of zero
8. BUTTON MODE = 0 for no button value output
9. FACTORY TEST commands not active
10. Maximum range scaling = 36 inches
11. Filter on/off status = AC WIDE notch on, DC on, AC NARROW notch off

12. Filter constants ALPHA_MIN Table values = 0.02
13. Filter constants ALPHA_MAX Table values = 0.9
14. Sudden output change lock = 0 allows sudden changes to be output
15. System measurement rate = 100 measurements/sec
16. SYNC mode = 0
17. Group Mode = 0

5.3 RS232 RESPONSE FORMAT

Two types of binary data are returned from The Bird: 1) Position/Orientation data and, 2) Change/Examine value data. Position/orientation data are the data returned from The Bird in the ANGLES, POSITION, MATRIX, POSITION/ANGLES, POSITION/MATRIX, POSITION/QUATERNION and QUATERNION formats. All other types of data that The Bird returns are in the change/examine value format. Both Position/Orientation data and the Change/Examine value data return one or more 8 bit data bytes as detailed below.

Position/Orientation data uses a special format, described in the following paragraphs. The Change/Examine value data uses the response format described with each Change/Examine value command in the RS232 Command section. The Change/Examine value data is not shifted and does not contain the 'phasing' bits found in the Position/Orientation data.

5.3.1 POSITION/ORIENTATION DATA FORMAT. The Position/Orientation information generated by The Bird is sent in a form called a data record. The number of bytes in each record is dependent on the output format selected by the user. Each 2-byte word is in a binary format dependent on the word type (i.e. Position, Angles, etc.). The binary formats consist of the 14 most significant bits (bits B15 - B2) of the sixteen bits (bits B15 - B0) which define each word. The two least significant bits (bits B1 and B0) are not used by The Bird. The first bit of the first byte transmitted is always a one (1) while the first bit of all other transmitted bytes in the record is always a zero (0). These "phasing" bits are required for the host computer to identify the start of a record when the data is streaming from The Bird without individual record requests. In general, the output data will appear as follows:

MS BIT									LS BIT	
	7	6	5	4	3	2	1	0		WORD #

1	B8	B7	B6	B5	B4	B3	B2	#1 LSbyte
0	B15	B14	B13	B12	B11	B10	B9	#1 MSbyte
0	C8	C7	C6	C5	C4	C3	C2	#2 LSbyte
0	C15	C14	C13	C12	C11	C10	C9	#2 MSbyte
0
0
0
0	N8	N7	N6	N5	N4	N5	N2	#N LSbyte
0	N15	N14	N13	N12	N11	N10	N9	#N MSbyte
0	0	0	AD4	AD3	AD2	AD1	AD0	GROUP MODE address

The MS (most significant) bits are the phasing bits, and are not part of the data. The GROUP MODE address byte is only present if GROUP MODE is enabled (see change value GROUP MODE).

For example, The Bird is about to send a data record consisting of these three data words:

Word#	Decimal	Hex	Binary (2 bytes)	
			MSbyte	LSbyte
#1	4386	1122	00010001	00100010
#2	13124	3344	00110011	01000100
#3	21862	5566	01010101	01100110

The conversion to the binary data format that The Bird does goes like this.

BIRD

- 1) Shifts each data word right one bit
- 2) Breaks each word into MSByte LSByte pairs

MS	LS	10010001	LS
00001000	10010001	00001000	MS
00011001	10100010	10100010	LS
00101010	10110011	00011001	MS
		10110011	LS
		00101010	MS

- 3) Shifts each LSByte right one more bit (Marks with "1" if first byte)
- 4) Transmits all bytes in stream

MS BIT				LS BIT				WORD #
7	6	5	4	3	2	1	0	
1	1	0	0	1	0	0	0	#1 LSByte
0	0	0	0	1	0	0	0	#1 MSByte
0	1	0	1	0	0	0	1	#2 LSByte
0	0	0	1	1	0	0	1	#2 MSByte
0	1	0	1	1	0	0	1	#3 LSByte
0	0	1	0	1	0	1	0	#3 MSByte

The user's computer can identify the beginning of the data record by catching the leading "1", and converting subsequent data bytes back to their proper binary values.

HOST:

- 1) Receives data bytes in stream after catching first marked "1" (Changes that "1" back to a "0")
- 2) Shifts each LSByte left one bit

01001000	LS	10010000	LS
00001000	MS	00001000	MS
01010001	LS	10100010	LS
00011001	MS	00011001	MS
01011001	LS	10110010	LS
00101010	MS	00101010	MS

- 3) Combines each MSByte/LSByte pair into data words
- 4) Shifts each word left one more bit, giving the correct original binary value

MS	LS	MS	LS
00001000	10010000	00010001	00100000
00011001	10100010	00110011	01000100
00101010	10110010	01010101	01100100

You don't need to worry about the fact that the two least significant bits are different because the data words do not use these bits.

NOTE: The GROUP MODE address and data sent by The Bird to the host in response to the BUTTON READ or EXAMINE VALUE commands are not shifted and have no phasing bit added.

5.4 COMMAND USAGE TABLE

The following information answers the question "To which Bird unit do I send a given command?" The answer depends on the type and number of interfaces (RS232 or RS485) and the command itself. The following table sorts out these possible combinations.

In the following, the word "flock" will mean several Bird units interconnected with FBB cables. "Bird" refers to a single unit with a sensor. "ERC" refers to the Extended Range Controller. "ERT" refers to the Extended Range Transmitter (the 12 inch black cube) that plugs into the ERC. The ERC does not have a sensor.

Applicability references

The command usage table refers to the numbers 2 to 6. Each of these number have the following meaning:

2. This command must be sent to the individual Bird in the Flock whose mode of operation you want to change even if you are in the **GROUP** mode. If you send this command addressed to the Master it will not change the mode of any other Bird. If you have an RS232 interface to each Bird individually (as many RS232 interfaces as there are Birds) then just send the command, they do not have to be prefaced with the **RS232 TO FBB** command. If you have only one RS232 or one RS485 interface (which must be attached to the Master Bird) to service the entire Flock then the commands must be prefaced with the **RS232 TO FBB** command.
3. This command is only sent to the Master unit. You may, but do not have to, use the **RS232 TO FBB** preface on commands meant for the Master unit only, in fact, if the **RS232 TO FBB** preface is missing, the Master assumes the command is for him alone.
4. Do not send this command to the address of the ERC.
5. Do not use this command if your system is using an ERC/ERT.
6. If in the **GROUP** mode send this command only to the Master.

 Notation shorthand

snsr = sensor

xmtr = transmitter

addr = address

exam/chg = examine/change

COMMAND USAGE TABLE

COMMAND	APPLICABILITY	NOTES
Angles	2, 4	Send to the addr of the snsr from which you want angles
Angle align	2, 4	Send to the addr of the snsr whose orientation you want to change. If you send it to the Master unit, the Master will not disseminate the information to the sensors.
Button mode	2, 4	Send to the addr of the snsr from which you want button outputs
Button read	2, 4	Send to the addr of the snsr from which you want button outputs
Examine value parameter 0 status	2	Send to the addr of the unit whose status you want to know
Examine value parameter 1 software rev	2	Send to the addr of the unit whose software rev you want to know
Examine value parameter 2 crystal speed	2	Send to the addr of the unit whose crystal speed you want to know
Exam/chg value parameter 3 Position Scaling	2, 4, 5	Send to the addr of the snsr whose range scaling you want to examine or change
Exam/chg value parameter 4 Filter on/off	2, 4	Send to the addr of the snsr whose filtering you want to examine or change
Exam/chg value parameter 5 Alpha min	2, 4	Send to the addr of the snsr whose filtering you want to examine or change

Exam/chg value parameter 6 measurement rate	3	If a Flock send to the Master only
---	---	------------------------------------

COMMAND	APPLICABILITY	NOTES
---------	---------------	-------

Exam/chg value parameter 8 enable data ready	3	If a Flock send to the Master only
Exam/chg value parameter 9 set data ready	3	If a Flock send to the Master only
Examine value parameter 10 error code	2	Send to the addr of the unit whose error code you want to know
Exam/chg value parameter 11 error mask	2	Send to the addr of The Bird unit where the error should be masked or examined
Exam/chg value parameter 12 DC filter V_m	2, 4	Send to the addr of the snsr whose filtering you want to examine or change
Exam/chg value parameter 13 alpha_max	2, 4	Send to the addr of the snsr whose filtering you want to examine or change
Exam/chg value parameter 14 output lock	2, 4	Send to the addr of the snsr whose outputs you want to lock or examine
Examine value parameter 15 identification	2	Send to the addr of the unit whose system model identification you want to know
Examine value parameter 16 expanded error	3	Send to the Master to determine the addr of the Slave that did not respond
Exam/chg value parameter 17 XYZ ref frame	2, 4	Send to the addr of the snsr whose outputs you want measured in the rotated xmtr frame
Exam/chg value parameter 18	3	Send to the Master only

Transmitter mode

Examine value parameter 19 Addressing mode	2	Send to the addr of The Bird unit whose addressing mode you want to examine
--	---	---

COMMAND APPLICABILITY NOTES

Exam/chg value parameter 20 Filter line freq	2, 4	Send to the addr of the snsr whose filtering you want to examine or change
Examine value parameter 21 FBB address	2	Send to The Bird unit whose FBB address you want to know. Useful when communicating to the Flock through multiple RS232 interfaces or through the ISA Bus
Exam/chg value parameter 22 Hemisphere	2, 4	Send to the addr of the snsr whose hemisphere you want to examine or change
Exam/chg value parameter 23 Angle align2	2, 4	Send to the addr of the snsr whose orientation you want to examine or change. If you send it to the Master unit, the Master will not disseminate the information to the sensors
Exam/chg value parameter 24 Reference frame2	2	Send to the addr with the transmitter whose reference frame you want to examine or change
Examine value parameter 25 Bird Serial Number	2, 4	Send to the addr of The Bird unit whose pcb serial number you want to know
Examine value parameter 26 Sensor Serial Number	2, 4	Send to the addr of The Bird unit whose snsr serial number you want to know
Examine value parameter 27 Xmtr Serial Number	2, 4	Send to the addr of The Bird unit whose xmtr serial number you want to know
Exam/chg value parameter 32 FBB host delay	2	Only applicable when using an RS485 interface
Exam/chg value parameter 35 Group mode	3	Send to the Master only to examine or change group mode

Examine value parameter 36 Flock status	3	Send to the Master only to examine Flock system status
Exam/chg value parameter 50 FBB auto-config	3	Send to the Master only
Factory test	2	DO NOT USE THIS COMMAND

COMMAND	APPLICABILITY	NOTES
FBB Reset	3	Send to the Master only
Hemisphere	2, 4	Send to the addr of the snsr whose outputs you want to be in a given hemisphere
Matrix	2, 4	Send to the addr of the snsr from which you want matrix data
Next transmitter	3	Send to the current Master only
Point	2, 6	If in Group mode send to the Master only. If not in group mode must use the RS232 TO FBB command to send to each individual sensor if you have only one interface port. If you have an RS232 interface port to each sensor then just send the point command out each port
Position	2, 4	Send to the addr of the snsr from which you want position data
Position/Matrix	2, 4	Send to the addr of the snsr from which you want position/matrix data
Position/Quaternion	2, 4	Send to the addr of the snsr from which you want position/quaternion data
Quaternion	2, 4	Send to the addr of the snsr from which you want quaternion data
Reference frame 3		Send to the Master before or after auto-config. After auto-config send to the addr with the transmitter. Can also be sent to the address of each sensor individually.
Report rate	6	Can only be used in standalone stream mode or in group stream mode
RS232 To FBB	3	Send to the Master only
Run	3	
Sleep	3	Send to the Master only

Sync	3	
Stream	6	Cannot be used with a Flock unless in GROUP mode
Xoff	3	
Xon	3	

6.0 FBB HOST INTERFACE

If your host computer is using the RS232 interface to the Flock then you need not read Section 6.x.

6.1 FBB SIGNAL DESCRIPTION

A pinout and signal description of the FBB interface is found below. Note that all FBB connectors are identical.

<u>PIN</u> ¹	<u>FBB SIGNAL</u>	<u>DIRECTION</u> ²	<u>LEVEL</u>
1	Not used		
2	FBB CTS+	Bidirectional	RS485/RS422
3	FBB CTS-	Bidirectional	RS485/RS422
4	FBB BIRD DATA+	Bidirectional	RS485/RS422
5	FBB BIRD DATA-	Bidirectional	RS485/RS422
6	FBB HOST DATA+	Bidirectional	RS485/RS422
7	FBB HOST DATA-	Bidirectional	RS485/RS422
8	GROUND	--	Ground

Notes:

- 1) Pin 1 is on the left when viewing the rear of The Bird.
- 2) Direction is defined with respect to The Bird.

FBB signals are described as follows:

<u>SIGNAL NAME</u>	<u>DESCRIPTION</u>
FBB CTS+/-	Clear to Send signal sent by the Master Bird to the host indicating that the host may transmit on the FBB HOST DATA lines. Signals are RS485 levels. This control line is currently not utilized; the host can always send data to The Birds.

<u>SIGNAL NAME</u>	<u>DESCRIPTION</u>
FBB BIRD DATA+/-	Serial Commands and Data transferred between Birds. The host must not use these signals. Signals are RS485 levels with serial data format as defined in the FBB Serial Data Format Section.
FBB HOST DATA+/-	Serial Commands and Data transferred between the host and The Birds. Signals are RS485 levels with serial data format as defined in the FBB Serial Data Format Section.
GROUND	Ground reference for the FBB.

6.1.1 FBB/RS485 TERMINATION. Signals with RS485/RS422 levels (FBB CTS, FBB BIRD DATA, and FBB HOST DATA) MUST BE terminated at both ends of the FBB bus via termination circuitry which is contained in all Birds. The termination blocks of Birds residing on the FBB which are not located at the ends MUST BE disabled by removing the termination jumpers.

6.2 FBB/RS485 HOST TRANSMISSION CHARACTERISTICS

FBB Commands and data are transferred over the FBB bus. The host computer can transmit commands and data whereas Slave Birds can only transmit data (in response to commands). The character format is defined as follows:

Baud Rate	57k to 500k baud (as set by Bird dipswitch.)
Number of data bits	8
Number of start bits	1
Number of stop bits	1
Parity	MARK - If sending a command SPACE -If sending data
Half duplex	

6.3 FBB/RS485 JUMPER CONFIGURATION

For host communications to The Bird using RS485 set the following jumpers. See Table 1 in Section 2.1.5 for a description of these jumpers.

<u>Jumper</u>	<u>Configuration</u>
JPR 3	pins 1-2 connected
JPR 12	pins 1-2 connected, pins 2-3 not connected
JPR 13	if present, pins 1-2 connected, pins 2-3 not connected
JPR 10	pins 1-2 connected on last Bird on the FBB
JPR 14	pins 1-2 connected on first and last Bird on the FBB
JPR 16	pins 1-2 connected on last Bird on the FBB
JPR 17	if present, pins 1-2 not connected

For host communications to the ERC using RS485 set the following jumpers. See Section 2.3.4 for a description of these jumpers.

<u>Jumper</u>	<u>Configuration</u>
JPR 14	pins 1-2 connected

Note: Also terminate the DATA and CTS signals on your host's RS485 interface card.

6.4 FBB/RS485 CONFIGURATION

Each Bird unit in the Flock contains two independent RS485 serial interfaces. The first interface is for communications between your host computer and the FOBs. The second interface is a dedicated RS485 interface for communications between the Flock members. The user and intra-flock RS485 buses are generically called the Fast Bird Bus (FBB). The user's host computer can utilize either a single high speed RS485 interface to talk to all Birds in the Flock or multiple RS485 interfaces (see Application Note #5). Using a single interface, the host can collect at least 100 data records per second of position/angle information from each of up to six Birds (Table 3). Since all Birds in the Flock communicate with each other via the FBB, you must interconnect each Bird in a daisy-chain fashion with the supplied cabling as indicated in Figures 1 and 4. To enable The Birds to exchange data among themselves or for your host computer to gather data from a given unit, each Bird is assigned a unique FBB address via the back-panel dipswitches. Set the Address = 1 on the unit designated as the Master. Set addresses 2 to 126 on all other units. Address = 0 is reserved for a standalone system, i.e., only one Bird unit. You cannot use the FBB/RS485 interface to talk to a standalone unit. But you can use this interface to talk to a Master Bird with Address = 1 and configured (see CHANGE VALUE command for FBB AUTO-CONFIGURATION) with one sensor, which is the equivalent of a standalone unit but using the FBB command set. Address 15 is the 'Broadcast' Address in Normal Address mode (31 in Expanded and 127 in Super-Expanded), used to send a command to all Birds on the bus simultaneously. When you use the FBB/RS485 interface on The Bird, you cannot use the RS232 interface to send commands or receive data. You may, however, use the RTS electrical signal on the RS232 interface to perform the functions of the FLY/STDBY switch on the front panel.

Table 4.
Maximum RS485 Data Record Output Rate When Using A Single RS485 Interface

DATA OUTPUT FORMAT (Records Output / Sec / Bird)				
Number of Sensors	Baud Rate	Position	Position/ Angles	Position/ Matrix
1 1 Master or 1 Slave	250K	1088	788	395
2 1 Master 1 Slave	250K	544	394	198
4 1 Master 3 Slave	250K	272	172	98
6 1 Master 5 Slave	250K	169	115	65
8 1 Master 7 Slave	250K	126	88	51
10 1 Master 9 Slave	250K	101	70	40

Notes: 1) The rates that are greater than 100 (The Bird's default measurement rate) are not meant to imply that each Bird is making this many measurements. Rather it indicates that you can request and receive data over the RS232 port at a rate greater than The Bird is making its measurements. When you request data at a rate greater than the measurement rate you will get duplicate data records. Rates less than 100 do not mean The Bird is making measurements this slowly. The Birds are always making 100 measurements per second per sensor independent of how many sensors are in a Flock. When you request data at a rate less than the measurement rate you will lose data records.

2) Rates for UNIX platforms will be much less than these table values.

3) Writes to the screen or disk will reduce these table values.

6.5 FBB COMMANDS

Each FBB command consists of a single Command Byte followed by N Command Data bytes, where N depends upon the command. A command is a 9 bit value which the host transmits to The Bird using the format shown below. The ninth bit is the parity which your host must force to be a 1 if sending a command or force to 0 if sending data.

The FBB command format is as follows:

	MS BIT										LS BIT
	Stop	Parity	7	6	5	4	3	2	1	0	Start
FBB Host											
Command	1	1	BC7	BC6	BC5	BA4	BA3	BA2	BA1	BA0	0
			<--FBB Command-->			<-----FBB Address----->					

where, BC7-BC5 is the 3 bit command value and BA4-BA0 is the 5 bit FBB address, and the MS BIT (Stop = 1), LS BIT (Start = 0) and Parity refer to the bit values that the 1UART in your host computer's RS485 port automatically inserts into the serial data stream as it leaves the computer. You must force parity = 1 when sending a command.

FBB command data bytes sent by the host to The Bird have the following format:

	MS BIT										LS BIT
	Stop	Parity	7	6	5	4	3	2	1	0	Start
FBB Host											
Command Data	1	0	BD7	BD6	BD5	BD4	BD3	BD2	BD1	BD0	0

where, BD7-BD0 is the 8 bit data value. You must force parity = 0 when sending data.

Note: The FBB Commands will not work in the Super Expanded Addressing mode.

6.5.1 FBB COMMAND SUMMARY. There are 8 (decimal) possible FBB host commands of which the following 5 are used:

FBB CMD	CMD BITS	COMMAND NAME	DESCRIPTION
	7 6 5		
0	0 0 0	FBB RS232CMD	Sends an RS232 command to The Bird using the FBB/RS485 interface
1	0 0 1	FBB SEND DATA	Requests a data record from The Bird
2	0 1 0	FBB SEND STATUS	Requests The Bird status record
3	0 1 1	FBB SEND ERROR	Requests the error code from The Bird
.	.	.	.
.	.	.	.
.	.	.	.
7	1 1 1	not used	Illegal commands

6.5.2 FBB COMMAND UTILIZATION. After switching the front panel switch of all The Birds in the Flock to FLY mode, the individual lights blink 5 times if in Normal Address mode, 2 times if in Expanded Address mode, or 1 time if in Super-Expanded Address mode then shut off. The Flock is not running yet. To get the entire Flock running utilize the FBB RS232CMD command to send to the Master unit only (the unit with the transmitter), the CHANGE VALUE FBB AUTO-CONFIGURATION command which is detailed in Section 9.0 under the CHANGE VALUE command. The host may then tell the individual Birds in the Flock what type of data to send when an FBB SEND DATA request is issued. By default, The Birds will send POSITION/ANGLE formatted data when a data request is received. To change the data type that will be sent, the host must utilize the FBB RS232CMD command to send one of the following data record commands: ANGLES, MATRIX, POSITION, POSITION/ANGLES, POSITION/MATRIX (see the individual command descriptions detailed in Section 9.0). These commands do not cause The Bird to transmit data to the host. For the host to receive data, it must issue an FBB SEND DATA request addressed to The Bird in the Flock from which it wants data or if GROUP mode is enabled a single FBB SEND DATA request sent to the Master will return data from all running Flock units.

The following is an example of a 1 transmitter, 3 sensor sequence of configuration commands (FBB address 1 has a transmitter and sensor, addresses 2 and 3 only have sensors):

<u>COMMAND</u>	<u>TO ADDRESS</u>	<u>ACTION</u>
RS232CMD its CHANGE VALUE FBB AUTO-CONFIG 3 Flock units	1 (the Master)	Bird 1 ARMs the Flock by disseminating transmitter information to Birds 2 and 3. If ARming goes OK, the Master sends the RUN command to the Slaves. Flock should be FLYing.
FBB RS232CMD POSITION	1	Bird 1 setup to output Position Data
FBB RS232CMD ANGLES	2	Bird 2 setup to output Angle Data
FBB RS232CMD POSITION/ANGLES	3	Bird 3 setup to output Position and Angles
FBB SEND STATUS	1	Host checks status of The Bird 1
FBB SEND DATA	1	Host get position data from Bird 1
FBB SEND DATA	2	Host get angle data from Bird 2
FBB SEND DATA	3	Host get position and angle from Bird 3

6.5.3 FBB BIRD DEFAULT VALUES. Upon power-up, The FBB controlled Bird (address 1 through 126) is in the following default mode:

1. POINT mode
2. POSITION/ANGLE outputs selected
3. XON
4. RUN deactivated
6. ANGLE ALIGN sines/cosines set for alignment angles of zero
7. REFERENCE FRAME sines/cosines set for reference angles of zero
8. BUTTON MODE = 0 for no button value output
9. FACTORY TEST commands not active
10. Maximum range scaling = 36 inches
11. Filter on/off status = AC WIDE notch on, DC on, AC NARROW notch off
12. Filter constant ALPHA_MIN = 0.02
13. Filter constant ALPHA_MAX = 0.9
14. Sudden output change lock = 1 does not allow sudden changes to be output
15. System measurement rate = 100 measurements/sec
16. SYNC mode = 0
17. FBB Configuration = 1 Transmitter, Multiple Sensors
18. FBB Devices = 0
19. FBB Dependents = 0
20. Group Mode = 0

6.6 FBB RESPONSES

Two types of binary data are returned from The Bird: 1) position/orientation data and 2) general status/configuration information. Both data types use the 8 bit data byte format as detailed below.

The FBB/RS485 command response data format is as follows:

MS BIT

LS BIT

	Stop	Parity	7	6	5	4	3	2	1	0	Start
FBB Host											
Response Data	1	0	BD7	BD6	BD5	BD4	BD3	BD2	BD1	BD0	0

where, BD7-BD0 is the 8 bit data value.

The data formats (BD7-BD0) for FBB responses are the same as those for RS232 responses. Refer to the RS232 RESPONSE Section 5.3 for specifics.

6.7 FBB COMMAND REFERENCE

FBB RS232CMD**FBB RS232CMD**

(Normal/Expanded)	FBB CMD	FBB Addr
Command Value	0	1-15/31

A Bird connected to the host via the FBB can utilize the RS232 command set by prefacing the RS232 command with the FBB RS232CMD. The FBB RS232CMD can be directed to one Bird or all Birds on the FBB. For example, suppose you want to put The Bird at address 2 into ANGLE mode via the FBB host interface. The host would send a 0 (the FBB RS232CMD command value) followed by a 2 (the address of The Bird), followed by a 57 Hex (the ANGLE command value). Another example would be the user 'broadcasting' the POSITION/MATRIX command to all Birds. In this case, the host would send a 0 Hex (FBB RS232CMD command value), F Hex (Broadcast Address if in Normal Address mode) or 1F Hex (Broadcast Address if in Expanded Address mode), and 5A Hex (command byte to select POSITION/MATRIX). The following RS232 commands are valid over the FBB host interface:

<u>COMMAND</u>		<u>HEX</u>	<u>ASCII</u>	<u>ADDRESS</u>
ANGLES		57	W	1 - 15/31
ANGLE ALIGN		4A	J	1 - 15/31
BUTTON MODE	4D	M		1 - 15/31
BUTTON READ		4E	N	1 - 14/30
CHANGE VALUE		50	P	1 - 15/31
EXAMINE VALUE		4F	O	1 - 14/30
FACTORY TEST		7A	z	1 - 15/31
FBB RESET		2F	/	1
MATRIX		58	X	1 - 15/31
NEXT TRANSMITTER		30		1 - 14
POSITION		56	V	1 - 15/31
POSITION/ANGLES		59	Y	1 - 15/31
POSITION/MATRIX		5A	Z	1 - 15/31
POSITION/QUATERNION		5D]	1 - 15/31
QUATERNION		5C	\	1 - 15/31
REFERENCE FRAME		48	H	1 - 15/31
RUN		46	F	1 - 15/31
SLEEP		47	G	1 - 15/31
SYNC		41	A	1 - 15/31
XOFF		13	<DC3>	1 - 15/31
XON		11	<DC1>	1 - 15/31

Note: The FBB Commands will not work in the Super-Expanded Addressing mode.

FBB SEND DATA

FBB SEND DATA

	FBB CMD	FBB Addr
(Normal/Expanded)		
Command Value	0	1-14/30

The specified Bird sends one data record each time it receives the FBB SEND DATA command. If GROUP mode is enabled, all Birds send a data record each time the Master receives the FBB SEND DATA command. The data format will be a function of the output mode, POSITION, ANGLES, MATRIX, POSITION/ANGLES, or POSITION/MATRIX. Refer to the RS232 command reference Section 9.0 for output format specifications.

FBB SEND STATUS**FBB SEND STATUS**

(Normal/Expanded)	FBB CMD	FBB Addr
Command Value	0	1-14/30

The FBB SEND STATUS command allows the user to determine The Bird's operational status. The Bird returns 1 byte of status information in response to this command. The format and content of the information returned from The Bird is the same as the most significant byte returned in response to The Bird STATUS command detailed in the RS232 EXAMINE VALUE section.

FBB SEND ERROR CODE**FBB SEND ERROR CODE**

(Normal/Expanded)	FBB CMD	FBB Addr
Command Value	0	1-14/30

The Bird maintains a SYSTEM ERROR register which can be queried by the host computer. When The Bird receives the FBB SEND ERROR CODE command, The Bird returns a 1 byte error code response. The byte is a binary representation of the first error The Bird encounters. Upon reading the SYSTEM ERROR register, The Bird resets the register to all 0's. Error codes and their meaning are described in the Error Messages section.

7.0 FLOCK OPERATIONAL LIMITATIONS

When in the Normal Address mode and using multiple sensors with one transmitter, the sensor closest to the transmitter controls the strength of the field emitted by the transmitter. This prevents a given sensor's electronics from being saturated by a very strong transmitted signal. As the closest sensor moves farther and farther away from the transmitter, the transmitter doubles and redoubles its output at appropriate transmitter-to-sensor separation distances. At some specified distance, the transmitter is at its maximum power and can no longer continue to double its output.

With multiple sensors, it is possible to have one sensor far from the transmitter while another sensor is close to the transmitter. Thus the sensor closest to the transmitter will command the transmitter to reduce its signal, resulting in a reduced signal at the farther sensor, hence the position and orientation measurements made by the farther sensor will contain additional noise.

For a Flock of Birds with the standard transmitter, the transmitter reaches full power when the transmitter-to-sensor separation is approximately 9 inches. Thus if all sensors operate at distances greater than 9 inches, no one sensor will suffer in performance. If one of the sensors moves to within 7 inches of the transmitter than the amount of noise in the measurements made by farther sensors will double. The table below gives the transmitter-to-sensor distances at which the transmitter doubles its power for both the standard range and extended range transmitters:

Xmtr power increase as a fraction of MAX power	Standard Range Xmtr. Range from center of xmtr (inches)	Extended Range Xmtr. Range from face of xmtr (inches)
0.25 to 0.5	7	24
0.5 to 1.0 (MAX POWER)	9	30

When operated in the Expanded Address mode or Super-Expanded Address mode (see Section 8.0) the sensor's location does not control the strength of the transmitter's field. The transmitter is always at full power. If the sensor saturates in the Expanded Address mode or Super-Expanded Address mode it outputs all zeroes for data.

8.0 TEST MODES

When the dipswitch position 8 is on (down) on the ERC or on an individual MotionStar sensor card in the chassis, the individual circuit card is in test mode and the light will blink at a regular rate. The user can select test 1 through 31 using dipswitches 4 through 7 as follows: (Remember you must toggle the power switch to initiate the desired test.)

DIPSWITCH					<u>Test Number</u>	<u>TEST</u>
<u>4</u>	<u>5</u>	<u>6</u>	<u>7</u>	<u>8</u>		
off	off	off	off	on	1	Factory Test
off	off	off	on	on	3	Bird Output
off	off	on	off	on	5	Bird Echo
off	off	on	on	on	7	Host Data Read
off	on	off	off	on	9	Host Data Read Block
off	on	off	on	on	11	Set 500K Baud Internal FBB
off	on	on	off	on	13	Set 625K Baud Internal FBB
off	on	on	on	on	15	<unused>
on	off	off	off	on	17	Factory Test
on	off	off	on	on	19	Factory Test
on	off	on	off	on	21	Test for sensor
on	off	on	on	on	23	Don't test for sensor
on	on	off	off	on	25	<unused>
on	on	off	on	on	27	Set Expanded Address mode
on	on	on	off	on	29	Set Normal Address Mode
on	on	on	on	on	31	Set Super-Expanded Address

Mode

Note: After power-up tests have successfully completed The Bird's LED will blink the following number of times depending on which address mode it is in:

Normal Addressing Mode	LED blinks 5 times
Expanded Addressing Mode	LED blinks twice
Super-Expanded Addressing Mode	LED blinks once

8.1 FACTORY TEST

The test is used during the manufacturing process of The Bird.

8.2 BIRD OUTPUT

During The Bird output test, The Bird will output 4 characters, 'O' (4F Hex), 'K' (4B Hex), <CR> (0D Hex), <LF> (0A Hex), approximately twice per second over either the FBB or

RS232 interface, depending on the host control mode. The user can validate his host cable and serial communication receive software with this test.

8.3 BIRD ECHO

During The Bird echo test, The Bird will echo every character received over either the FBB or RS232 interface. Using this test, the user can validate the host interface hardware and software.

8.4 HOST DATA READ

During the host data read test, The Bird will send one 8 bit character, 0 through 255 decimal, each time it receives any character over either the FBB or RS232 interface. The first character sent by The Bird will be a 0, then a 1, 2, 3 and so on. Using this test, the user can verify that his host computer can receive all binary characters. This will help UNIX users to configure the serial port (TTY) to assure that the operating system is passing all 8 bit characters.

8.5 HOST DATA READ BLOCK

During the host data read block test, The Bird will send a block of 8 bit characters, 0 through 255 decimal, each time it receives any character over either the FBB or RS232 interface. The block consists of 256 characters where the first will be a 0, then a 1, 2, 3 and so on. Using this test, the user can verify that his computer's operating system can receive a large number of binary characters at the desired baud rate without problems.

8.6 TEST FOR SENSOR

Selecting this test burns a bit into an on board eeprom memory that tells The Bird to test for the presence of a sensor on powerup. This is the default factory setting. If a sensor is not attached to The Bird on powerup the LED on the circuit card will blink an error code and the error register will be set.

8.7 DON'T TEST FOR SENSOR

Selecting this test burns a bit into an on board eeprom memory that tells The Bird not to test for the presence of a sensor on powerup. If a sensor is not attached to The Bird there will be no error blinking or error reporting while this no test bit is burned in. It is useful to set this condition if you are using your Bird in a multi-card configuration where a given card may only have a transmitter and not a sensor.

8.8 SET NORMAL ADDRESS MODE

This sets the ERC and Bird sensors into Normal Addressing Mode, which enables FBB addresses 1 through 14. The mode is stored in the internal non-volatile memory. To set the unit into Normal Addressing Mode, select test #29 and turn the power on. When the front panel indicator blinks, Normal Addressing Mode has been set. The dipswitch can then be reset with the correct baud rate and address. The power switch must then be cycled for Normal Address operation. The ERC and all Bird sensor cards must be individually set to Normal Address mode. When a Bird is in Normal Address mode its light will blink 5 times and then goes out when it is powered-up.

8.9 SET EXPANDED ADDRESS MODE

This sets the ERC and Bird sensors into Expanded Addressing Mode, which enables FBB addresses 1 through 30. To set the unit into Expanded Addressing Mode, select test #27 and turn the power on. When the front panel indicator blinks, Expanded Addressing Mode has been set. The dipswitch can then be reset with the proper address and baud rate. The power switch must then be cycled for Expanded Address operation. The ERC and all Bird sensor cards must be individually set to Expanded Address mode. When a Bird is in Expanded Address mode its light will blink 2 times and then go out when it is powered-up.

8.10 SET SUPER-EXPANDED ADDRESS MODE

This sets the ERC and Bird sensors into Super-Expanded Addressing Mode, which enables FBB addresses 1 through 126. To set the unit into Super-Expanded Addressing Modes, select test #31 and turn the power on. When the front panel indicator blinks, Super-Expanded Addressing Mode has been set. The dipswitch can then be reset with the proper address and baud rate. The power switch must then be cycled for Super-Expanded Address operation. The ERC and all Bird sensor cards must be individually set to Super-Expanded Address Mode. When a Bird is in Super-Expanded Address

mode its light will blink 1 time and then go out when it is powered-up.

9.0 RS232 COMMAND REFERENCE

All commands are listed alphabetically in the following section. Each command description contains the command codes required to initiate the commands, as well as the format and scaling of the data records which The Bird will output to the host computer.

ANGLES

ANGLES

	ASCII	HEX	DECIMAL
BINARY			
Command Byte	W	57	87
01010111			

In the ANGLES mode, The Bird outputs the orientation angles of the sensor with respect to the transmitter. The orientation angles are defined as rotations about the Z, Y, and X axes of the sensor. These angles are called Zang, Yang, and Xang or, in Euler angle nomenclature, Azimuth, Elevation, and Roll. The output record is in the following format for the six transmitted bytes:

MSB								LSB	
7	6	5	4	3	2	1	0		BYTE #
1	Z8	Z7	Z6	Z5	Z4	Z3	Z2		#1 LSbyte Zang
0	Z15	Z14	Z13	Z12	Z11	Z10	Z9		#2 MSbyte Zang
0	Y8	Y7	Y6	Y5	Y4	Y3	Y2		#3 LSbyte Yang
0	Y15	Y14	Y13	Y12	Y11	Y10	Y9		#4 MSbyte Yang
0	X8	X7	X6	X5	X4	X3	X2		#5 LSbyte Xang
0	X15	X14	X13	X12	X11	X10	X9		#6 MSbyte Xang

Zang (Azimuth) takes on values between the binary equivalent of +/- 180 degrees. Yang (Elevation) takes on values between +/- 90 degrees, and Xang (Roll) takes on values between +/- 180 degrees. As Yang (Elevation) approaches +/- 90 degrees, the Zang (Azimuth) and Xang (Roll) become very noisy and exhibit large errors. At 90 degrees the Zang (Azimuth) and Xang (Roll) become undefined. This behavior is not a limitation of The Bird - it is an inherent characteristic of these Euler angles. If you need a stable representation of the sensor orientation at high Elevation angles, use the MATRIX output mode.

The scaling of all angles is full scale = 180 degrees. That is, +179.99 deg = 7FFF Hex,

0 deg = 0 Hex, -180.00 deg = 8000 Hex.

Angle information is 0 when sensor saturation occurs in Expanded Addressing mode or Super-Expanded Addressing mode.

To convert the numbers into angles first cast it into a signed integer. This will give you a number from +/- 32767. Second multiply by 180 and finally divide the number by 32767 to get the angle. The equation should look something like this:

$$(\text{signed int}(\text{Hex \#}) * 180) / 32767$$

ANGLE ALIGN1**ANGLE ALIGN1**

	ASCII	HEX	DECIMAL
BINARY			
Command Byte 01001010	J	4A	74

Command Data	Sin(A)	Cos(A)	Sin(E)	Cos(E)	Sin(R)	Cos(R)
--------------	--------	--------	--------	--------	--------	--------

By default, the angle outputs from The Bird are measured in the coordinate frame defined by the transmitter's X, Y and Z axes, as shown in Figure 7, and are measured with respect to rotations about the physical X, Y and Z axes of the sensor. The ANGLE ALIGN1 command allows you to mathematically change the sensor's X, Y and Z axes to an orientation which differs from that of the actual sensor.

For example:

Suppose that during installation you find it necessary, due to physical requirements, to cock the sensor, resulting in its angle outputs reading Azim = 5 deg, Elev = 10 and Roll = 15 when it is in its normal "resting" position. To compensate, use the ANGLE ALIGN1 command, passing as Command Data the sines and cosines of 5, 10 and 15 degrees. After this sequence is sent, the sensor outputs will be zero, and orientations will be computed as if the sensor were not misaligned.

Note: the ANGLE ALIGN1 command only affects the computation of orientation - it has no effect on position.

If you immediately follow the ANGLE ALIGN1 command with a POINT or STREAM mode data request, you may not see the effect of the ALIGN command in the data returned. It will take at least one measurement period (i.e. 10 milliseconds if running The Bird at 100 measurements/sec) before you see the effect of the command.

The host computer must send the Command Data immediately following the Command Byte. The Command Data consists of the sines and cosines of the Azimuth (A), Elevation (E), and Roll (R) angles that specify the amount of sensor misalignment you want to remove. Use the ANGLE ALIGN2 command for sending the angles instead of the sines and cosines of the angles. The Command Data must be sent even if the angles are zero. The Command Byte and Command Data must be transmitted to The Bird in the following thirteen-byte format:

MSB								LSB			
7	6	5	4	3	2	1	0	BYTE #			
0	1	0	0	1	0	1	0	#1	Command Byte		
B7	B6	B5	B4	B3	B2	B1	B0	#2	LSbyte SIN(A)		
B15	B14	B13	B12	B11	B10	B9	B8	#3	MSbyte SIN(A)		
B7	B6	B5	B4	B3	B2	B1	B0	#4	LSbyte COS(A)		
B15	B14	B13	B12	B11	B10	B9	B8	#5	MSbyte COS(A)		
B7	B6	B5	B4	B3	B2	B1	B0	#6	LSbyte SIN(E)		
B15	B14	B13	B12	B11	B10	B9	B8	#7	MSbyte SIN(E)		
B7	B6	B5	B4	B3	B2	B1	B0	#8	LSbyte COS(E)		
B15	B14	B13	B12	B11	B10	B9	B8	#9	MSbyte COS(E)		
B7	B6	B5	B4	B3	B2	B1	B0	#10	LSbyte SIN(R)		
B15	B14	B13	B12	B11	B10	B9	B8	#11	MSbyte SIN(R)		
B7	B6	B5	B4	B3	B2	B1	B0	#12	LSbyte COS(R)		
B15	B14	B13	B12	B11	B10	B9	B8	#13	MSbyte COS(R)		

The sine and cosine elements take values between the binary equivalents of +.99996 and -1.0.

Element scaling is +.99996 = 7FFF Hex, 0 = 0 Hex, and -1 = 8000 Hex.

ANGLE ALIGN2

ANGLE ALIGN2

	ASCII	HEX	DECIMAL
BINARY			
Command Byte 011110001	q	71	113

Command Data	A, E, R
--------------	---------

Same as the ANGLE ALIGN1 command except that the command data consists of the angles only and not the sines and cosines of the angles.

The Command Byte and Command Data must be transmitted to The Bird in the following seven-byte format:

MSB							LSB	
7	6	5	4	3	2	1	0	BYTE #
0	1	1	1	0	0	1	0	#1 Command Byte
B7	B6	B5	B4	B3	B2	B1	B0	#2 LSbyte A
B15	B14	B13	B12	B11	B10	B9	B8	#3 MSbyte A
B7	B6	B5	B4	B3	B2	B1	B0	#4 LSbyte E
B15	B14	B13	B12	B11	B10	B9	B8	#5 MSbyte E
B7	B6	B5	B4	B3	B2	B1	B0	#6 LSbyte R
B15	B14	B13	B12	B11	B10	B9	B8	#7 MSbyte R

See the ANGLES command for the format and scaling of the angle values sent.

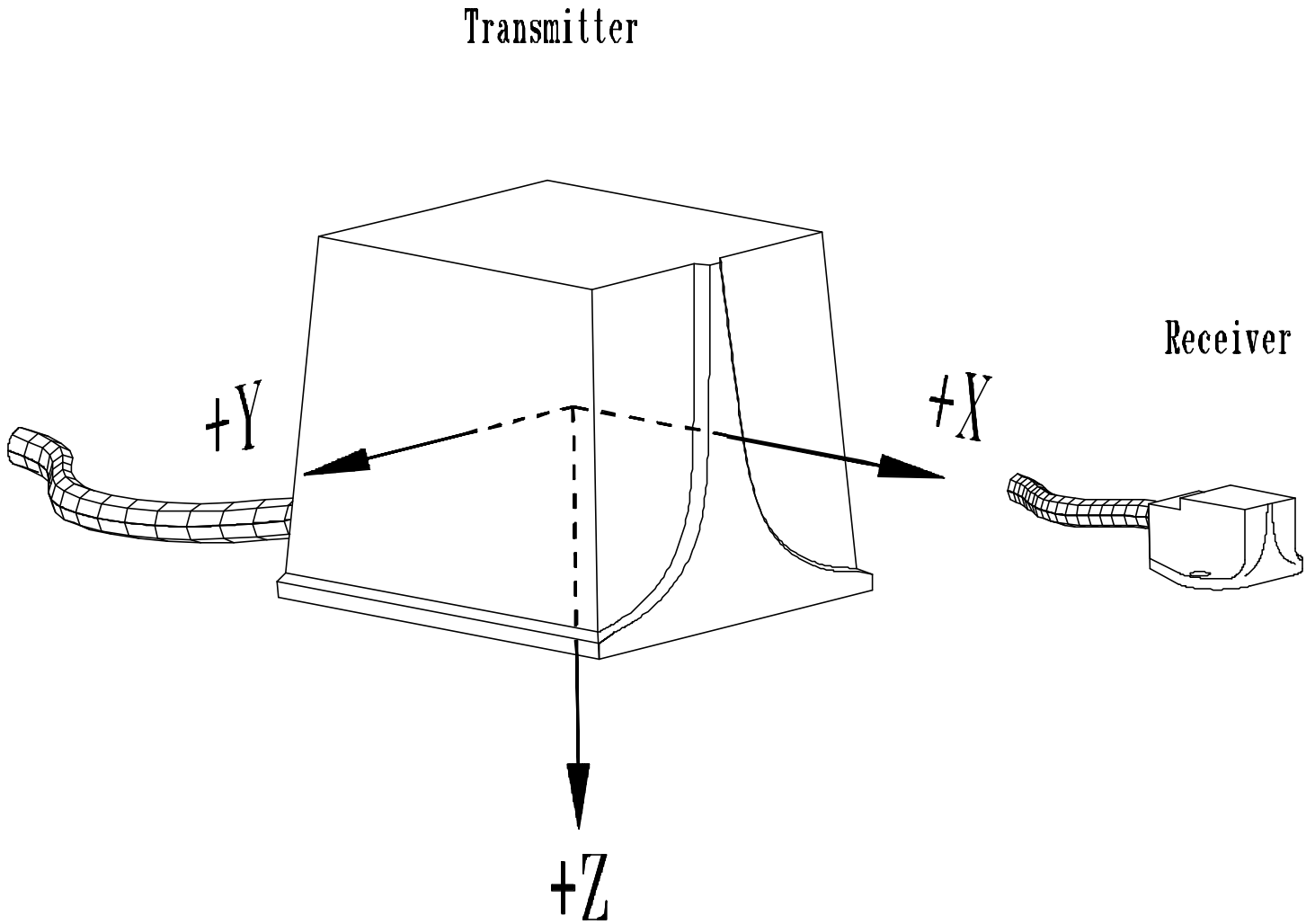

Figure 7. Measurement Reference Frame

BUTTON MODE

BUTTON MODE

	ASCII	HEX	DECIMAL
BINARY			
Command Byte 01001101	M	4D	77

Command Byte	MODE
--------------	------

The BUTTON MODE command is used to set how the three buttons on the optional Bird 6D mouse will be reported to the host computer. The BUTTON MODE Command Byte must be followed by a single Command Data byte which specifies the desired report format. The three buttons are reported to the host via a single Button Value byte. This byte can be sent by The Bird after the last data record element is transmitted, or can be read at any time using the BUTTON READ command. If you set the Command Data byte equal to 0 Hex, the Button Value byte is not appended to the data record, and you must use the BUTTON READ command to examine the status of the buttons. If you set the Command Data byte equal to 1, the Button Value byte will be appended to the end of each transmitted data record. If, for example, you had selected the POSITION/ANGLE mode, the output sequence would now be: x, y, z, az, el, rl, button, for a total of 13 bytes instead of the normal 12 bytes.

The BUTTON MODE command must be issued to The Bird in the following 2-byte sequence:

MSB								LSB	BYTE #
7	6	5	4	3	2	1	0		
0	1	0	0	1	1	0	1		#1 Command Byte
0	0	0	0	0	0	0	D0		#2 Command Data

Where D0 is either 0 or 1.

For a description of the values which may be returned in the Button Value byte, see the **BUTTON READ** command.

BUTTON READ**BUTTON READ**

	ASCII	HEX	DECIMAL
BINARY			
Command Byte 01001110	N	4E	78

The BUTTON READ command allows you to determine at any time which of the three buttons on the optional Bird 6D mouse was pressed. This command is especially useful when you want to read the buttons but do not have BUTTON MODE set to 1 (which would append the Button Value byte to every transmitted record).

Immediately after you send the BUTTON READ Command Byte, The Bird will return a single byte containing the button value. The Button Value byte can assume the following Hex values:

- 0 Hex = 0: No button pressed.
- 10 Hex = 16: Left button pressed.
- 30 Hex = 48: Middle (or middle and left) button pressed.
- 70 Hex = 112: Right (or right and any other) button pressed.

Notes: The Button Value byte does not contain the phasing bits normally included in The Bird's transmitted data records. The above values are the ones actually sent to the host.

The Bird updates its button reading every 0.01 seconds, whether you request the value or not. Thus, the system does not store previous button presses, and indicates only whether a button has been pressed within 0.01 seconds (at the default update rate) of the time the reading is sent to the host.

**CHANGE VALUE
EXAMINE VALUE**

**CHANGE VALUE
EXAMINE VALUE**

	ASCII	HEX	DECIMAL
BINARY CHANGE VALUE Command Byte 0101000	P	50	87

CHANGE VALUE Command Byte	PARAMETERnumber	PARAMETERvalue
------------------------------	-----------------	----------------

The CHANGE VALUE command allows you to change the value of The Bird system parameter defined by the PARAMETERnumber byte and the PARAMETERvalue byte(s) sent with the command.

	ASCII	HEX	DECIMAL
BINARY EXAMINE VALUE Command Byte 01001111	O	4F	79

EXAMINE VALUE Command Byte	PARAMETERnumber
-------------------------------	-----------------

The EXAMINE VALUE command allows you to read the value of The Bird system

parameter defined by the PARAMETERnumber sent with the command. Immediately after The Bird receives the command and command data, it will return the parameter value as a multi-byte response.

Valid CHANGE VALUE and EXAMINE VALUE PARAMETERnumbers are listed in the table below. Note: not all PARAMETERnumbers are CHANGEable, but ALL are EXAMINEable.

<u>PARAMETERnumber</u>		<u>CHANGEable</u>	<u>PARAMETER DESCRIPTION</u>
Dec	Hex		
0	0	No	Bird status
1	1	No	Software revision number
2	2	No	Bird computer crystal speed
3	3	Yes	Position scaling
4	4	Yes	Filter on/off status
5	5	Yes	DC Filter constant table ALPHA_MIN
6	6	Yes	Bird measurement rate count
7	7	Yes	Bird measurement rate
8	8	Yes	Disable/Enable data ready output character
9	9	Yes	Changes data ready character
10	A	No	Bird outputs an error code
11	B	Yes	On error: stop or don't stop Bird operation
12	C	Yes	DC filter constant table Vm
13	D	Yes	DC filter constant table ALPHA_MAX
14	E	Yes	Sudden output change elimination
15	F	No	System Model Identification
16	10	No	Expanded Error Code
17	11	Yes	XYZ Reference Frame
18	12	Yes	Transmitter Operation Mode
19	13	No	FBB addressing mode
20	14	Yes	Filter line frequency
21	15	No	FBB address
22	16	Yes	Change/Examine Hemisphere
23	17	Yes	Change/Examine Angle Align2
24	18	Yes	Change/Examine Reference Frame2
25	19	No	Bird Serial Number

26	1A	No	Sensor Serial Number
27	1B	No	Xmtr Serial Number
32	20	Yes	FBB Host Delay
35	23	Yes	Group Mode
36	24	No	Flock System Status
50	32	Yes	FBB Auto-Configuration - 1 xmtr/N snsr

The CHANGE VALUE command must be issued to The Bird in the following N-byte sequence:

MSB							LSB		
7	6	5	4	3	2	1	0	BYTE #	
0	1	0	1	0	0	0	0	#1 Command Byte, 'P'	
N7	N6	N5	N4	N3	N2	N1	N0	#2 PARAMETERnumber	
B7	B6	B5	B4	B3	B2	B1	B0	#3 PARAMETERdata LSbyte	
B7	B6	B5	B4	B3	B2	B1	B0	#4 PARAMETERdata MSbyte	
B7	B6	B5	B4	B3	B2	B1	B0	#N PARAMETERdata	

Where, N7-N0 represent a PARAMETERnumber (i.e. 00000011 or 00000100), and B7-B0 represent N-bytes of PARAMETERdata. If the PARAMETERdata is a word then the Least Significant byte (LSbyte) is transmitted before the Most Significant byte (MSbyte). If the PARAMETERdata is numeric, it must be in 2's complement format. You do not shift and add 'phasing' bits to the data.

The EXAMINE VALUE command must be issued to The Bird in the following 2-byte sequence:

MSB							LSB		
7	6	5	4	3	2	1	0	BYTE #	
0	1	0	0	1	1	1	1	#1 Command Byte	

N7 N6 N5 N4 N3 N2 N1 N0 #2 PARAMETERnumber

Where N7-N0 represent a PARAMETERnumber, i.e. 00000000 or 00000001, etc.

If the PARAMETERdata returned is a word then the Least Significant byte (LSbyte) is received before the Most Significant byte (MSbyte). If the PARAMETERdata is numeric, it is in 2's complement format. The PARAMETERdata received does not contain 'phasing' bits. The PARAMETERdata value, content and scaling depend on the particular parameter requested. See the following discussion of each parameter.

BIRD STATUS

When PARAMETERnumber = 0, during EXAMINE, The Bird returns a status word to tell the user in what mode the unit is operating. The bit assignments for the two byte response are:

B15	1 if Bird is a Master Bird 0 if Bird is a Slave Bird
B14	1 if Bird has been initialized (AUTO-CONFIGURED) 0 if Bird has not been initialized
B13	1 if an error has been detected 0 if no error is detected
B12	1 if Bird is RUNNING 0 if Bird is not RUNNING
B11	1 if in HOST SYNC mode 0 if not in HOST SYNC mode
B10	1 if Expanded Address mode enabled 0 if Normal Address mode enabled

Note: If you are in Super-Expanded Address mode this command will still report that the Expanded Address mode is enabled and you

will have to use the FBB Addressing Mode command to find out which Addressing mode is actually enabled.

B9	1 if in CRTSYNC mode 0 if not in CRTSYNC mode
B8	1 if no sync modes are enabled 0 if a sync mode is enabled
B7	1 if the factory test and Bird commands are enabled 0 if only The Bird commands are enabled
B6	1 if XOFF 0 if XON
B5	1 if The Bird is in SLEEP mode. Same as B12 0 if The Bird is in RUN mode
B4, B3, B2, B1	0001 if POSITION outputs selected 0010 if ANGLE outputs selected 0011 if MATRIX outputs selected 0100 if POSITION/ANGLE outputs selected 0101 if POSITION/MATRIX outputs selected 0110 factory use only 0111 if QUATERNION outputs selected 1000 if POSITION/QUATERNION outputs selected
B0	0 if POINT mode selected 1 if STREAM mode selected

SOFTWARE REVISION NUMBER

When PARAMETERnumber = 1, during EXAMINE, The Bird returns the revision number of the software located in The Bird's PROM memory. The revision number in base 10 is expressed as INT.FRA where INT is the integer part of the revision number and FRA is the fractional part. For example, if the revision number is 2.13 then INT = 2 and FRA = 13. The value of the most significant byte returned is INT. The value of the least

significant byte returned is FRA. Thus, in the above example the value returned in the most significant byte would have been 02 Hex and the value of the least significant byte would have been 0D Hex. If the revision number were 3.1 then the bytes would be 03 and 01 Hex.

BIRD COMPUTER CRYSTAL SPEED

When PARAMETERnumber = 2, during EXAMINE, The Bird returns the speed of its computer's crystal in megahertz (MHz). You need to know the crystal speed if you want to determine or set the measurement rate of The Bird or compute the vertical scan rate of your CRT. The most significant byte of the speed word is equal to zero, and the base 10 value of the least significant byte represents the speed of the crystal. For example, if the least significant byte = 19 Hex, the crystal speed is 25 MHz.

POSITION SCALING

When PARAMETERnumber = 3, during EXAMINE, The Bird returns a code that describes the scale factor used to compute the position of the sensor with respect to the transmitter. If the separation exceeds this scale factor, The Bird's position outputs will not change to reflect this increased distance, rendering the measurements useless. The most significant byte of the parameter word returned is always zero. If the least significant byte = 0, the scale factor is 36 inches for a full scale position output. If the least significant byte is = 1, the full scale output is 72 inches. Do not use this command with the Extended Range Transmitter (ERT). Full scale output for the ERT is 144 inches and is not changeable.

To CHANGE the scale factor send The Bird two bytes of PARAMETERdata with the most significant byte set to zero and the least significant set to zero or one.

Note: Changing the scale factor from the default 36 inches to 72 inches reduces by half the resolution of the output X, Y, Z coordinates.

Regardless of the scale factor setting, operation of The Bird at ranges beyond the specified 48-inch operating range is not recommended. At these increased ranges, The

Bird's outputs will exhibit increased noise and reduced dynamic response. If the increased noise is too great for your application, use the CHANGE VALUE command on the ALPHA_MIN filter parameter.

FILTER ON/OFF STATUS

When PARAMETERnumber = 4, during EXAMINE, The Bird returns a code that tells you what software filters are turned on or off in the unit. The average user of The Bird should not have to change the filters, but it is possible to do so. The most significant byte returned is always zero. The bits in the least significant byte are coded per the following:

<u>BIT NUMBER</u>	<u>MEANING</u>
B7-B3	0
B2	0 if the AC NARROW notch filter is ON 1 if the AC NARROW notch filter is OFF (default)
B1	0 if the AC WIDE notch filter is ON (default)

	1 if the AC WIDE notch filter is OFF
B0	0 if the DC filter is ON (default) 1 if the DC filter is OFF

The AC NARROW notch filter refers to a two tap finite impulse response (FIR) notch filter that is applied to signals measured by The Bird's sensor to eliminate a narrow band of noise with sinusoidal characteristics. Use this filter in place of the AC WIDE notch filter when you want to minimize the transport delay between Bird measurement of the sensor's position/orientation and the output of these measurements. The transport delay of the AC NARROW notch filter is approximately one third the delay of the AC WIDE notch filter.

The AC WIDE notch filter refers to a six tap FIR notch filter that is applied to the sensor data to eliminate sinusoidal signals with a frequency between 30 and 72 hertz. If your application requires minimum transport delay between measurement of the sensor's position/orientation and the output of these measurements, you may want to evaluate the effect on your application with this filter shut off and the AC NARROW notch filter on. If you are running The Bird synchronized to a CRT, you can usually shut this filter off without experiencing an increase in noise.

Note: For optimal notch filter performance make sure that The Bird is set for the proper Line Frequency by checking it with the FILTER LINE FREQUENCY command.

The DC filter refers to an adaptive, infinite impulse response (IIR) low pass filter applied to the sensor data to eliminate high frequency noise. Generally, this filter is always required in the system unless your application can work with noisy outputs. When the DC filter is turned on, you can modify its noise/lag characteristics by changing ALPHA_MIN and Vm.

To CHANGE the FILTER ON/OFF STATUS send The Bird two bytes of PARAMETERdata with the most significant byte set to zero and the least significant set to the code in the table above.

DC FILTER CONSTANT TABLE ALPHA_MIN

When PARAMETERnumber = 5, during EXAMINE, The Bird returns 7 words (14 bytes)

which define the lower end of the adaptive range that filter constant ALPHA_MIN can assume in the DC filter as a function of sensor to transmitter separation. When ALPHA_MIN = 0 Hex, the DC filter will provide an infinite amount of filtering (the outputs will never change even if you move the sensor). When ALPHA_MIN = 0.99996 = 7FFF Hex, the DC filter will provide no filtering of the data.

The default values as a function of transmitter to sensor separation range for the standard range and extended range transmitters are:

Std. Range Xmtr Range (inches)	Extended Range Xmtr Range (inches)	ALPHA_MIN (decimal)
0 to 17	0 to 55	0.02 = 028F Hex.
17 to 22	55 to 70	0.02
22 to 27	70 to 90	0.02
27 to 34	90 to 110	0.02
34 to 42	110 to 138	0.02
42 to 54	138 to 170	0.02
54 +	170 +	0.02

To CHANGE ALPHA_MIN, send The Bird seven words of PARAMETERdata corresponding to the ALPHA_MIN table defined above. At the shorter ranges you may want to increase ALPHA_MIN to obtain less lag while at longer ranges you may want to decrease ALPHA_MIN to provide more filtering (less noise/more lag). If you decrease the value below 0.008, the output noise will actually increase due to loss of mathematical precision. ALPHA_MIN must always be less than ALPHA_MAX.

BIRD MEASUREMENT RATE COUNT

When PARAMETERnumber = 6, during EXAMINE, The Bird returns a word that is used to determine the measurement rate of the unit. The word returned represents a timer count (XMTR_TIME_CNT) that determines how long each of The Bird's three transmitter antennas will be turned on/off. From this word, you can estimate the total measurement period. XMTR_TIME_CNT is returned with values from 0000 to FFFF Hex or 0 to 65535 decimal. See The Bird MEASUREMENT RATE command below for a simpler form of this command.

The measurement rate in cycles/sec is computed from:

$$\text{measurement rate} = 1000 / (4.0 * \text{XTIME} + 0.3)$$

Where XTIME in milliseconds is:

$$\text{XTIME} = \text{XMTR_TIME_CNT} * \text{CLOCK} / 1000$$

where CLOCK is the period of one computer time count in microseconds. With a crystal value equal to 40 MHz, $\text{CLOCK} = 8/40$. The crystal value is determined by using the command EXAMINE VALUE Bird COMPUTER CRYSTAL SPEED.

The Bird's measurement rate is nominally set for 103 measurements/sec. If, however, The Bird is synchronized to your CRT (see CRT SYNC command), the measurement rate will automatically increase. If you reduce the measurement rate after you are synchronized, The Bird will drop out of synchronization. To regain synchronization, reissue the CRT SYNC command = 2. Increasing the rate will not cause loss of synchronization nor will it result in an increased measurement rate beyond the retrace rate of the CRT.

To CHANGE the MEASUREMENT RATE COUNT send The Bird one word of PARAMETERdata corresponding to XMTR_TIME_CNT defined above.

You can increase The Bird's measurement rate to a maximum of 144 measurements/sec. The downside of going to rates faster than 103 measurements/sec is that the noise on your outputs may increase and any errors introduced by nearby metals will increase.

You can decrease The Bird's measurement rate to no less than 20 measurements/sec for 40 MHz Birds. It is at this value that XMTR_TIME_CNT reaches its maximum value of 65535. Decreasing the measurement rate is useful if you need to reduce errors resulting from highly conductive metals such as aluminum. If you have low-conductive, highly permeable metals in your environment such as carbon steel or iron, changing the measurement rate will not change the distortions. For low-conductive, low permeability metals such as 300 series stainless steel or nickel, speed changes will have minimal effect, since in this case, the metal is not introducing any errors into The Bird's measurements anyway.

The downside of decreasing The Bird's measurement rate is that dynamic performance is decreased. That is, if you move The Bird's sensor quickly, the slow measurement rate will cause increased lag errors. Also, at slower rates the noise will increase or decrease, depending on the rate you choose. For example, the noise will be at a maximum if you select a measurement rate equal to your power line frequency of 50 or 60 hertz.

As you change the measurement rate of The Bird, you may want to experiment with changing the filter characteristics. For example, the AC filter is optimized for a measurement rate of 103 measurements/sec. At very low measurement rates you may want to shut this filter off.

BIRD MEASUREMENT RATE

When PARAMETERnumber = 7, during EXAMINE, The Bird returns a word that is used to determine the measurement rate of the unit. The word returned is the measurement rate in cycles/sec times 256.

The measurement rate in cycles/sec is computed from:

$$\text{measurement rate} = (\text{word returned}) / 256.$$

To CHANGE the MEASUREMENT RATE, send The Bird one word of PARAMETERdata corresponding to (measurement rate) * 256.

The MEASUREMENT RATE command is a simpler form of the MEASUREMENT RATE COUNT command. Refer to the MEASUREMENT RATE COUNT command regarding speed limits and metal distortion versus noise tradeoffs.

DISABLE/ENABLE DATA READY OUTPUT

Enabling the DATA READY character provides a method for notifying you as soon as the newest position and orientation data has been computed. Typically, you would issue a POINT data request as soon as you receive the DATA READY command. If you are running in STREAM mode you should not use the DATA READY character since the position and orientation is sent to you automatically as soon as it is ready.

When PARAMETERnumber = 8, during EXAMINE, The Bird outputs one byte of data, equal to 1 if Data Ready Output is enable or a 0 if disabled. If you are using the FBB interface, only the Master Bird will output the DATA READY character, since the data is ready at the same time from all Flock members. If you are using an RS232 interface, each Bird that has its DATA READY output enabled will output the DATA READY character.

To CHANGE DATA READY, send The Bird one byte of PARAMETERdata = 1 if The Bird is to output the Data Ready Character every measurement cycle as soon as a new measurement is ready for output. The default Data Ready Character is a comma (2C Hex, 44 Dec).

SET DATA READY CHARACTER

When PARAMETERnumber = 9, during EXAMINE, The Bird returns one byte, the current Ascii value of the Data Ready Character.

To CHANGE the DATA READY CHARACTER, send The Bird one byte of PARAMETERdata equal to the character value that The Bird should use as the Data Ready Character.

ERROR CODE

When PARAMETERnumber = 10, during EXAMINE, The Bird will output a one byte Error register code, defined in the Error Message Section 10.0. The error code is reset to all 0's after it has been read.

ERROR DETECT MASK

When PARAMETERnumber = 11, during EXAMINE, The Bird returns one byte which is the ERROR DETECT MASK. IF ERROR DETECT MASK = 0, The Bird, when it detects an error, will perform as defined in the Error Message Section 10.0. If ERROR DETECT

MASK = 1, then FATAL errors which would stop The Bird and blink the error code continuously, only blink the message once and try to continue Bird operation. If ERROR DETECT MASK = 3 then error messages that are FATAL or WARNING1 level do not blink the error code at all, and do not stop Bird operation, but the Error register is updated.

To CHANGE the ERROR DETECT MASK send to The Bird one byte of PARAMETERdata with a value of 0, 1 or 3 as defined above.

DC FILTER TABLE Vm

When PARAMETERnumber = 12, during EXAMINE, The Bird returns a 7 word (14 byte) table, or during CHANGE, the user sends to The Bird a 14 byte table representing the expected noise that the DC filter will measure. By changing the table values the user can increase or decrease the DC filter's lag as a function of sensor range from the transmitter.

The DC filter is adaptive in that it tries to reduce the amount of low pass filtering in The Bird as it detects translation or rotation rates in The Bird's sensor. Reducing the amount of filtering results in less filter lag. Unfortunately electrical noise in the environment, when measured by the sensor, also makes it look like the sensor is undergoing a translation and rotation. As the sensor moves farther and farther away from the transmitter, the amount of noise measured by the sensor appears to increase because the measured transmitted signal level is decreasing and the sensor amplifier gain is increasing. In order to decide if the amount of filtering should be reduced, The Bird has to know if the measured rate is a real sensor rate due to movement or a false rate due to noise. The Bird gets this knowledge by the user specifying what the expected noise levels are in the operating environment as a function of distance from the transmitter. These noise levels are the 7 words that form the Vm table. The Vm values can range from 1 for almost no noise to 32767 for a lot of noise.

The default values as a function of transmitter to sensor separation range for the standard range and extended range transmitters are:

Std. Range Xmtr Range (inches)	Extended Range Xmtr Range (inches)	Vm (integer)
0 to 17	0 to 55	2
17 to 22	55 to 70	4
22 to 27	70 to 90	8
27 to 34	90 to 110	32
34 to 42	110 to 138	64
42 to 54	138 to 170	256
54 +	170 +	512

As Vm increases with range so does the amount of filter lag. To reduce the amount of lag reduce the larger Vm values until the noise in The Bird's output is too large for your application.

DC FILTER CONSTANT TABLE ALPHA_MAX

When PARAMETERnumber = 13, during EXAMINE, The Bird returns 7 words (14 bytes) which define the upper end of the adaptive range that filter constant ALPHA_MAX can assume in the DC filter as a function of sensor to transmitter separation. When there is a fast motion of the sensor, the adaptive filter reduces the amount of filtering by increasing the ALPHA used in the filter. It will increase ALPHA only up to the limiting ALPHA_MAX value. By doing this, the lag in the filter is reduced during fast movements. When ALPHA_MAX = 0.99996 = 7FFF Hex, the DC filter will provide no filtering of the data during fast movements.

The default values as a function of transmitter to sensor separation range for the standard range and extended range transmitters are:

Std. Range Xmtr Range (inches)	Extended Range Xmtr Range (inches)	ALPHA_MAX (fractional)
0 to 17	0 to 55	0.9 = 07333 Hex.
17 to 22	55 to 70	0.9
22 to 27	70 to 90	0.9
27 to 34	90 to 110	0.9
34 to 42	110 to 138	0.9
42 to 54	138 to 170	0.9
54 +	170 +	0.9

To CHANGE ALPHA_MAX send The Bird seven words of PARAMETERdata corresponding to ALPHA_MAX. During CHANGE, you may want to decrease ALPHA_MAX to increase the amount of filtering if The Bird's outputs are too noisy during rapid sensor movement. ALPHA_MAX must always be greater than ALPHA_MIN.

SUDDEN OUTPUT CHANGE LOCK

When PARAMETERnumber = 14, during EXAMINE, The Bird returns a byte which indicates if the position and orientation outputs will be allowed to change if the system detects a sudden large change in the outputs. Large undesirable changes may occur at large separation distances between the transmitter and sensor when the sensor undergoes a fast rotation or translation. The byte returned will = 1 to indicate that the outputs will not be updated if a large change is detected. If the byte returned is zero, the outputs will change.

To change SUDDEN OUTPUT CHANGE LOCK send The Bird one byte of PARAMETERdata = 0 to unlock the outputs or send one byte = 1 to lock the outputs.

SYSTEM MODEL IDENTIFICATION

When PARAMETERnumber = 15, during EXAMINE, The Bird returns 10 bytes which will represent the device that was found.

Device Description String	Device
"6DFOB "	Stand alone (SRT)
"6DERC "	Extended Range Controller
"6DBOF "	MotionStar (old name)
"PCBIRD "	pcBIRD
"SPACEPAD "	SpacePad
"MOTIONSTAR"	MotionStar (new name)
"WIRELESS "	MotionStar Wireless

EXPANDED ERROR CODE

When PARAMETERnumber = 16, during EXAMINE, The Bird will output two bytes describing the error code with expanded error information. The first byte output is the Error register code as defined in examine value with PARAMETERnumber = 10 and the second byte is the expanded error code information which is additional information describing why the error occurred.

Expanded error information is only useful when the first byte, the error code, is 13 (No FBB Command Response). When in Normal Addressing mode the least significant 4 bits of the second byte contain the address (1 through 14) of the Slave which did not respond to the Master. When in Expanded Addressing mode the least significant 5 bits contain the address (1 through 30) of the Slave which did not respond to the Master. The remaining most significant bits contain factory diagnostic information and should be ignored. When in Super-Expanded Addressing mode the least significant 7 bits contain the address (1 through 126) of the Slave which did not respond to the Master.

XYZ REFERENCE FRAME

By default, the XYZ measurement frame is the reference frame defined by the physical orientation of the transmitter's XYZ axes even when the REFERENCE FRAME command has been used to specify a new reference frame for measuring orientation angles. When PARAMETERnumber = 17, during CHANGE, if the one byte of PARAMETER DATA sent to The Bird is = 1 then the XYZ measurement frame will also correspond to the new reference frame defined by the REFERENCE FRAME command. When the PARAMETER DATA sent is a zero then the XYZ measurement frame reverts to the orientation of the transmitter's physical XYZ axes.

During EXAMINE, The Bird returns a byte value of 0 or 1 to indicate that the XYZ measurement frame is either the transmitter's physical axes or the frame specified by the REFERENCE FRAME command.

TRANSMITTER OPERATION MODE

When PARAMETERnumber = 18, during EXAMINE, The Bird returns a byte that is used to determine the current Transmitter Mode. The byte value returned may take one of the following valid values: (This value is contained in the least significant 7 bits of the byte).

- | | |
|---|------------------|
| 0 | Non-Pulsed mode |
| 1 | Pulsed mode |
| 2 | "Cool-Down" mode |

Some waveforms cannot be used with some Flock components, so care must be taken if this command is used.

Note: The miniBIRD transmitter circuits cannot operate in Non-Pulsed mode. Running the Non-Pulsed mode on the miniBIRD will immediately destroy the transmitter drive circuits. The miniBIRD automatically defaults to the "Cool-Down" mode, and may be run in the Pulsed mode. The miniBIRD as FBB Master will ignore the Non-Pulsed mode command.

Note: The pcBIRD transmitter circuits cannot operate in Non-Pulsed mode. Running the Non-Pulsed mode on the pcBIRD over a long period of time will damage the transmitter drive circuits. The pcBIRD automatically defaults to the "Cool-Down" mode, and may be run in the Pulsed mode. The pcBIRD as the FBB Master will ignore the Non-Pulsed

mode command.

All Flock of Bird components may be run in Pulsed mode.

To CHANGE the current transmitter mode send the Master Bird one byte of PARAMETERdata corresponding to the codes described above.

Note: The Pulsed mode offers better dynamic performance. The Non-Pulsed mode offers better resistance to metal distortion.

FBB ADDRESSING MODE

When PARAMETERnumber = 19, during EXAMINE, The Bird returns a byte that contains a value which defines the current FBB addressing mode. The following are the valid values for the addressing mode:

0	NORMAL	(FBB address range = 1 -> 14)
1	EXPANDED	(FBB address range = 1 -> 30)
3	SUPER-EXPANDED	(FBB address range = 1 -> 126)

This parameter cannot be CHANGED.

FILTER LINE FREQUENCY

When PARAMETERnumber = 20, during EXAMINE, The Bird returns a byte whose value is the Line Frequency which is being used to determine the Wide Notch Filter coefficients. The default Line Frequency is 60 Hz.

To CHANGE the Line Frequency send 1 byte of PARAMETERdata corresponding to the desired Line Frequency. The range of Line Frequencies available are 1 -> 255.

Example: To change the Line Frequency to 50Hz you would first send a Change Value command (50 Hex), followed by a Filter Line Frequency command (14 Hex), followed by the line frequency for 50 Hz (32 Hex).

FBB ADDRESS

When PARAMETERnumber = 21, during EXAMINE, The Bird will return a byte corresponding to its current FBB address. Useful when communicating to the Flock through multiple RS232 interfaces or through the ISA Bus.

CHANGE/EXAMINE HEMISPHERE

When PARAMETERnumber = 22, during EXAMINE, The Bird will return 2 bytes of data defining the current Hemisphere. These are as follows:

Hemisphere	HEMI_AXIS		HEMI_SIGN	
	ASCII	HEX	ASCII	HEX
Forward	nul	00	nul	00
Aft (Rear)	nul	00	soh	01
Lower		ff	0C	nul
Upper	ff	0C	soh	01
Right	ack	06	nul	00
Left	ack	06	soh	01

Note: These are the same PARAMETERdata values as are used by the HEMISPHERE command 'L' (4C Hex).

To CHANGE the Hemisphere send 2 PARAMETERdata bytes as described above.

Note: This command operates in exactly the same way as the HEMISPHERE command. The command is now included in the CHANGE/EXAMINE command set in order to allow users to examine the values which were previously inaccessible.

Note: The values can only be EXAMINED with this command if they were previously CHANGED by this command.

CHANGE/EXAMINE ANGLE ALIGN2

When PARAMETERnumber = 23, during EXAMINE, The Bird will return 3 words (6 bytes) of data corresponding to the Azimuth, Elevation, and Roll angles used in the ANGLE ALIGN2 command. This command differs from the ANGLE ALIGN2 command only in that it allows both reading and writing of the angles. See ANGLE ALIGN2 for a full explanation of its use.

To CHANGE the angles send 6 bytes of PARAMETERdata after the 2 command bytes.

Note: The angles can only be read back with this command if they were previously written with this command, i.e. if the ANGLE ALIGN2 (or the ANGLE ALIGN) was used to set the angles, then those angles will not be accessible with the EXAMINE ANGLE ALIGN2 command.

CHANGE/EXAMINE REFERENCE FRAME2

When PARAMETERnumber = 24, during EXAMINE, The Bird will return 3 words (6 bytes) of data corresponding to the Azimuth, Elevation and Roll angles used in the REFERENCE FRAME2 command.

See REFERENCE FRAME2 command for an explanation.

To CHANGE the angles send 6 bytes of PARAMETERdata after the 2 command bytes.

Note: These angles are only accessible with this command if they were previously written with this command.

BIRD SERIAL NUMBER

When PARAMETERnumber = 25, during EXAMINE, The Bird will return a 1 word (2 byte) value corresponding to the Serial Number of The Bird electronic unit.

Note: This number cannot be changed.

SENSOR SERIAL NUMBER

When PARAMETERnumber = 26, during EXAMINE, The Bird will return a 1 word (2 byte) value corresponding to the Serial Number of The Bird's sensor. You can not swap sensors while The Bird is switched to FLY. If you do you will get the Serial Number of the sensor that was attached to The Bird when it was first turned on.

Note: This number cannot be changed.

XMTR SERIAL NUMBER

When PARAMETERnumber = 27, during EXAMINE, The Bird will return a 1 word (2 byte) value corresponding to the Serial Number of The Bird's transmitter. You can not swap transmitters while The Bird is switched to FLY. If you do you will get the Serial Number of the transmitter that was attached to The Bird when it was first turned on.

Note: This number cannot be changed.

FBB HOST RESPONSE DELAY

When PARAMETERnumber = 32, during EXAMINE, The Bird returns a word corresponding to the minimum time it will take The Bird to respond to an FBB command. The word is in units of 10 uS. Therefore, if a value of 14 Hex (20 Decimal) is returned, The Bird will wait 200 uS to drive the half duplex FBB DATA lines. The FBB HOST RESPONSE DELAY value can be increased if the host is polling its UART's received data ready signal, or if the host cannot turn its transceiver to receive fast enough prior to The Bird starting its response. This command has no effect when using the full-duplex RS232 interface.

To CHANGE the FBB HOST RESPONSE DELAY send The Bird one word of PARAMETERdata corresponding to the delay count defined previously.

GROUP MODE

The GROUP MODE command is only used if you have multiple Birds working together in a Master/Slave configuration and you want to get data from all The Birds by talking to only the Master Bird.

When PARAMETERnumber = 35, during EXAMINE VALUE, The Bird will respond with one byte of data indicating if The Bird is in GROUP MODE. If the data is a 1 then The Bird is in GROUP MODE and if the data is 0 The Bird is not in GROUP MODE. When in GROUP MODE, in response to the POINT or STREAM commands, the Master Bird will send data records from all running Birds with sensors residing on the FBB. Information is output from The Bird with the smallest address first. The last byte of the data record from each Bird contains the address of that Bird. This address byte contains no phasing bits. Each Bird can be in a different data output format if desired. For example, if 3

units are in the Flock, and the first is configured to output POSITION data only (6 data bytes plus 1 address byte) and the other two are configured to output POSITION/ANGLES data (12 data bytes plus 1 address byte) then the Master Bird will respond with 33 bytes when a data request is made.

During a CHANGE VALUE command, the host must send one data byte equal to a 1 to enable GROUP MODE or a 0 to disable GROUP MODE.

FLOCK SYSTEM STATUS

When PARAMETERnumber = 36, during EXAMINE, the Master Bird returns to the host computer 14 bytes (30 bytes if in Expanded Address mode, 126 bytes if in Super-Expanded Address mode) defining the physical configuration of each Bird on the bus. This command can be sent to the Master either before or after the Flock is running. The response has the following format, where one byte is returned for each possible FBB address:

BYTE 0	- address 1 configuration
BYTE 1	- address 2 configuration
.	.
.	.
.	.
BYTE 13 (29/125)	- address 14 (30/126) configuration

Each byte has the following format:

BIT 7	If 1, device is accessible on FBB. If 0, device is not accessible. A device is accessible when its fly switch is on. It may or may not be running.
BIT 6	If 1, device is running. If 0, device is not running. A device is running when the power switch is on, it has been AUTO-CONFIGed and it is AWAKE. A device is not running when the power switch is

	on and it has not been AUTO-CONFIGed or it has been AUTO-CONFIGed and it is ASLEEP.
BIT 5	If 1, device has a sensor. If 0, device does not have a sensor
BIT 4	If 1, transmitter is an ERT. If 0, transmitter is standard range
BIT 3	If 1, ERT #3 is present. If 0, not present
BIT 2	If 1, ERT #2 is present. If 0, not present
BIT 1	If 1, ERT #1 is present. If 0, not present
BIT 0	If 1, ERT #0 or standard range transmitter is present. If 0, not present

FBB AUTO-CONFIGURATION

The AUTO-CONFIGURATION command is used to start running multiple Birds working together in a Master/Slave configuration or a single Bird with an Extended Range Transmitter.

When PARAMETERnumber = 50, during an CHANGE VALUE command, the Master Bird will perform all the necessary configurations of the Slaves and itself for a one transmitter/multiple sensor configuration. The Master Bird expects one byte of data corresponding to the number of Bird electronic units on the FBB that should be used in the 1 transmitter/multiple sensor mode. For example, if the one byte = 3 then The Bird at address = 1 (the default Master) will assume that there are also Birds at addresses 2 and 3. These three Bird units will then start running. If you have an Extended Range Transmitter Controller (ERC) in your configuration then the ERC counts as one Bird electronics unit. Note that contiguous addresses must be used (i.e., for 1 transmitter 5 sensors, Birds with addresses 1 through 5 must be present). The command sequence would look like 50 (Hex), followed by a 32 (Hex), followed by a 3.

When the number of Bird units is set = 1, the Master is using only its sensor with its transmitter. This allows you to operate like a standalone unit but you must use the FBB commands. In this mode, your host computer can use either the FBB/RS485 or the RS232 interface. In the standalone mode, you can use only the RS232 interface.

Once the Flock is running, the AUTO-CONFIGURATION command can also be used to reconfigure a Flock. For example if the Flock is currently AUTO-CONFIGURED with 3 Bird units, you can reconfigured with 2 Bird units by sending AUTO-CONFIGURATION command with 2 as the data while the Flock is in operation.

Resending AUTO-CONFIGURATION to the Master after an error develops in the Flock will many times clear the error and restart the system.

If you have GROUP STREAM mode running, you must first terminate STREAM mode before sending another AUTO-CONFIGURATION command.

Before sending the AUTO-CONFIGURATION command, you must wait at least 600 milliseconds to allow any previous commands to complete. After sending the AUTO-CONFIGURATION command you must also wait at least 600 milliseconds before sending another command.

When PARAMETERnumber = 50, during an EXAMINE VALUE command, The Bird returns 5 bytes of FBB configuration information when in Normal Addressing mode, 7 bytes when in Expanded Addressing mode, or 19 bytes when in Super-Expanded Addressing mode. Three pieces of information are passed, FBB CONFIGURATION MODE, FBB DEVICES, and FBB DEPENDENTS. FBB CONFIGURATION MODE, indicates the current Bird configuration as either Standalone or One Transmitter/Multiple Sensors mode. FBB DEVICES is used to tell which Birds on the FBB are running. FBB DEPENDENTS informs The Birds which Slaves on the FBB will be using the signal transmitted from the current Master.

The bit definitions of the bytes are:

<u>BYTE 0</u>	<u>FBB CONFIGURATION MODE</u>
0	STANDALONE
1	ONE TRANSMITTER/MULTIPLE SENSORS
<u>BYTES 1, 2</u>	<u>FBB DEVICES</u>

BIT 15	0
BIT 14	If 1, device at address 14 is running If 0, device at address 14 is not running
	A Bird is RUNNING when the fly switch is on, it has been AUTO-CONFIGed and it is AWAKE. A device is not running when the fly switch is on and it has not been AUTO-CONFIGed or it has been AUTO-CONFIGed and it is ASLEEP.
BIT 13	If 1, device at address 13 is running If 0, device at address 13 is not running
.	.
.	.
BIT 1	If 1, device at address 1 is running If 0, device at address 1 is not running
BIT 0	0
<u>BYTES 3, 4</u>	<u>FBB DEPENDENTS</u>
BIT 15	0
BIT 14	If 1, device at address 14 is dependent If 0, device at address 14 is not dependent
BIT 13	If 1, device at address 13 is dependent If 0, device at address 13 is not dependent
.	.
.	.
BIT 1	If 1, device at address 1 is dependent If 0, device at address 1 is not dependent
BIT 0	0

FACTORY TEST**FACTORY TEST**

	ASCII	HEX	DECIMAL
BINARY			
Command Byte 01111010	z	7A	122

The FACTORY TEST mode is intended for factory diagnostic use only. The user should not use this command.

FBB RESET**FBB RESET**

	ASCII	HEX	DECIMAL
BINARY			
Command Byte 00101111	/	2F	47

This command when sent to the Master on the FBB will cause all of the Slaves to be reset through the FBB. A typical initialization procedure would be as follows:

Do a hardware reset of the Master by toggling the RTS line on the RS232 interface to the Master. After the Master has been reset and is running issue this FBB RESET command to the Master and the Master will reset all of the Slaves through the FBB.

Note: The Reset Jumper (jumper 17 on The Bird, jumper 11 on the ERC) must be in place on all of the Slaves, but not on the Master Bird in order for this command to work.

HEMISPHERE

HEMISPHERE

	ASCII	HEX	DECIMAL
BINARY			
Command Byte	L	4C	76
01001100			

Command Data	HEMI_AXIS	HEMI_SIGN
--------------	-----------	-----------

The shape of the magnetic field transmitted by The Bird is symmetrical about each of the axes of the transmitter. This symmetry leads to an ambiguity in determining the sensor's X, Y, Z position. The amplitudes will always be correct, but the signs (\pm) may all be wrong, depending upon the hemisphere of operation. In many applications, this will not be relevant, but if you desire an unambiguous measure of position, operation must be either confined to a defined hemisphere or your host computer must 'track' the location of the sensor.

There is no ambiguity in the sensor's orientation angles as output by the ANGLES command, or in the rotation matrix as output by the MATRIX command.

The HEMISPHERE command is used to tell The Bird in which hemisphere, centered about the transmitter, the sensor will be operating. There are six hemispheres from which you may choose: the forward, aft (rear), upper, lower, left, and the right. If no HEMISPHERE command is issued, the forward is used by default.

The two Command Data bytes, sent immediately after the HEMISPHERE command, are to be selected from these:

Hemisphere	HEMI_AXIS		HEMI_SIGN	
	ASCII	HEX	ASCII	HEX
Forward	nul	00	nul	00
Aft (Rear)	nul	00	soh	01

Upper	ff	0C	soh	01
Lower	ff	0C	nul	00
Left	ack	06	soh	01
Right	ack	06	nul	00

The ambiguity in position determination can be eliminated if your host computer's software continuously 'tracks' the sensor location. In order to implement tracking, you must understand the behavior of the signs (\pm) of the X, Y, and Z position outputs when the sensor crosses a hemisphere boundary. When you select a given hemisphere of operation, the sign on the position axes that defines the hemisphere direction is forced to positive, even when the sensor moves into another hemisphere. For example, the power-up default hemisphere is the forward hemisphere. This forces X position outputs to always be positive. The signs on Y and Z will vary between plus and minus depending on where you are within this hemisphere. If you had selected the lower hemisphere then the sign of Z would always be positive and the signs on X and Y will vary between plus and minus. If you had selected the left hemisphere then the sign of Y would always be negative, etc.

Returning to the default forward hemisphere, if the sensor moved into the aft hemisphere then the signs on Y and Z would instantaneously change to opposite polarities while the sign on X remained positive. To 'track' the sensor, your host software, on detecting this sign change, would reverse the signs on The Bird's X, Y, and Z outputs. In order to 'track' correctly: You must start 'tracking' in the selected hemisphere so that the signs on the outputs are initially correct and you must guard against the case where the sensor legally crossed the Y = 0, Z = 0 axes simultaneously without having crossed the X = 0 axes into the other hemisphere.

MATRIX

MATRIX

	ASCII	HEX	DECIMAL
BINARY			
Command Byte	X	58	88
01011000			

The MATRIX mode outputs the 9 elements of the rotation matrix that define the orientation of the sensor's X, Y, and Z axes with respect to the transmitter's X, Y, and Z axes. If you want a three-dimensional image to follow the rotation of the sensor, you must multiply your image coordinates by this output matrix.

The nine elements of the output matrix are defined generically by:

```

*
*           M( 1 , 1 )           M( 1 , 2 )           M( 1 , 3 )           *
*
*           M( 2 , 1 )           M( 2 , 2 )           M( 2 , 3 )           *
*
*           M( 3 , 1 )           M( 3 , 2 )           M( 3 , 3 )           *
*

```

Or in terms of the rotation angles about each axis where Z = Zang, Y = Yang and X = Xang:

```

*
* COS ( Y ) * COS ( Z )           COS ( Y ) * SIN ( Z )           -SIN ( Y )           *
*
* -COS ( X ) * SIN ( Z )           COS ( X ) * COS ( Z )           *

```

*+SIN(X)*SIN(Y)*COS(Z)	+SIN(X)*SIN(Y)*SIN(Z)	SIN(X)*COS(Y)*
*		*
*		*
* SIN(X)*SIN(Z)	-SIN(X)*COS(Z)	*
*+COS(X)*SIN(Y)*COS(Z)	+COS(X)*SIN(Y)*SIN(Z)	COS(X)*COS(Y)*
*		*

Or in Euler angle notation, where R = Roll, E = Elevation, A = Azimuth:

```

*
* COS ( E ) * COS ( A )          COS ( E ) * SIN ( A )          -SIN ( E )          *
*
*
* -COS ( R ) * SIN ( A )          COS ( R ) * COS ( A )          *
* +SIN ( R ) * SIN ( E ) * COS ( A )  +SIN ( R ) * SIN ( E ) * SIN ( A )  SIN ( R ) * COS ( E ) *
*
*
* SIN ( R ) * SIN ( A )          -SIN ( R ) * COS ( A )          *
* +COS ( R ) * SIN ( E ) * COS ( A )  +COS ( R ) * SIN ( E ) * SIN ( A )  COS ( R ) * COS ( E ) *
*

```

The output record is in the following format for the eighteen transmitted bytes:

	MSB				LSB				
	7	6	5	4	3	2	1	0	BYTE #
1	M8	M7	M6	M5	M4	M3	M2		#1 LSbyte M(1,1)
0	M15	M14	M13	M12	M11	M10	M9		#2 MSbyte M(1,1)
0	M8	M7	M6	M5	M4	M3	M2		#3 LSbyte M(2,1)
0	M15	M14	M13	M12	M11	M10	M9		#4 MSbyte M(2,1)
0	M8	M7	M6	M5	M4	M3	M2		#5 LSbyte M(3,1)
0	M15	M14	M13	M12	M11	M10	M9		#6 MSbyte M(3,1)
0	M8	M7	M6	M5	M4	M3	M2		#7 LSbyte M(1,2)
0	M15	M14	M13	M12	M11	M10	M9		#8 MSbyte M(1,2)
0	M8	M7	M6	M5	M4	M3	M2		#9 LSbyte M(2,2)
0	M15	M14	M13	M12	M11	M10	M9		#10 MSbyte M(2,2)
0	M8	M7	M6	M5	M4	M3	M2		#11 LSbyte M(3,2)
0	M15	M14	M13	M12	M11	M10	M9		#12 MSbyte M(3,2)
0	M8	M7	M6	M5	M4	M3	M2		#13 LSbyte M(1,3)
0	M15	M14	M13	M12	M11	M10	M9		#14 MSbyte M(1,3)
0	M8	M7	M6	M5	M4	M3	M2		#15 LSbyte M(2,3)
0	M15	M14	M13	M12	M11	M10	M9		#16 MSbyte M(2,3)
0	M8	M7	M6	M5	M4	M3	M2		#17 LSbyte M(3,3)
0	M15	M14	M13	M12	M11	M10	M9		#18 MSbyte M(3,3)

The matrix elements take values between the binary equivalents of +.99996 and -1.0. Element scaling is +.99996 = 7FFF Hex, 0 = 0 Hex, and -1.0 = 8000 Hex.

Matrix information is 0 when sensor saturation occurs in Expanded Addressing mode or Super-Expanded Addressing mode.

NEXT TRANSMITTER

NEXT TRANSMITTER

	HEX	DECIMAL	BINARY
Command Byte	30	48	00110000
Command Data	TRANSMITTER ADDR and TRANSMITTER NUM		

If you have multiple transmitters in your Flock and you want to turn on a transmitter other than the transmitter at FBB address 1, use the NEXT TRANSMITTER command. This command is sent to the current Master with a single byte of command data containing the FBB address (1 to 14) and the transmitter number (0 to 3) of the next transmitter you want to turn on. The transmitter number for the standard three foot operating range Flock transmitter is always 0. The transmitter number for the optional Extended Range Controller (ERC) can be 0, 1, 2 or 3 depending on which of the four transmitters is being used on the ERC. At the end of its current measurement cycle (1 to 10 milliseconds after the command is received), the addressed Bird starts its transmitter.

Next Transmitter command data format:

MSB							LSB
7	6	5	4	3	2	1	0
A3	A2	A1	A0	0	0	N1	N0

Where A3-A0 is the FBB address of the Next Transmitter,

<u>A3</u>	<u>A2</u>	<u>A1</u>	<u>A0</u>	
0	0	0	1	- Address 1
0	0	1	0	- Address 2
		.		
		.		
		.		
1	1	1	0	- Address 14

And N1-N0 is the number of the NEXT TRANSMITTER at the FBB address,

<u>N1</u>	<u>N0</u>	
0	0	- Number 0
0	1	- Number 1
1	0	- Number 2
1	1	- Number 3

Therefore, to turn on the transmitter 2 at FBB address = 6, the command byte is 30H followed by a command data byte of 62H

Notes:

- 1) With multiple transmitters, the measurement reference frame is defined with respect to the location and orientation of the transmitter that is currently turned on. Thus, unless each transmitter is aligned perfectly to each other, you will get a jump in the measured orientation of the sensor when the next transmitter is turned on. To overcome the angular misalignments you can use the REFERENCE FRAME command directed to each transmitter after you powerup the Flock but before you do the transmitter switching.
- 2) If you select a transmitter that is not available then the Master will indicate error 29, 'transmitter not accessible'

POINT**POINT**

	ASCII	HEX	DECIMAL
BINARY			
Command Byte 01000010	B	42	66

In the POINT mode, The Bird sends one data record each time it receives the B Command Byte. When in GROUP MODE, the Master Bird will output a record for each running Bird in the Flock (see EXAMINE/CHANGE parameter number 35). Remember, when GROUP MODE is enabled an extra byte containing the FBB address of The Bird is added to the end of each data record.

POSITION

POSITION

	ASCII	HEX	DECIMAL
BINARY			
Command Byte	V	56	86
01010110			

In the POSITION mode, The Bird outputs the X, Y, and Z positional coordinates of the sensor with respect to the transmitter. The output record is in the following format for the six transmitted bytes:

	MSB							LSB	
	7	6	5	4	3	2	1	0	BYTE #
	1	X8	X7	X6	X5	X4	X3	X2	#1 LSbyte X
	0	X15	X14	X13	X12	X11	X10	X9	#2 MSbyte X
	0	Y8	Y7	Y6	Y5	Y4	Y3	Y2	#3 LSbyte Y
	0	Y15	Y14	Y13	Y12	Y11	Y10	Y9	#4 MSbyte Y
	0	Z8	Z7	Z6	Z5	Z4	Z3	Z2	#5 LSbyte Z
	0	Z15	Z14	Z13	Z12	Z11	Z10	Z9	#6 MSbyte Z

The X, Y, and Z values vary between the binary equivalent of ± MAX inches. Where MAX = 36" or 72" if using a standard range transmitter or MAX = 144" if using an extended range transmitter. The positive X, Y, and Z directions are shown in Figure 7.

Scaling of each position coordinate is full scale = MAX inches. That is, +MAX = 7FFF Hex, 0 = 0 Hex, -MAX = 8000 Hex. Since the maximum range (Range = square root(X**2+Y**2+Z**2)) from the transmitter to the sensor is limited to MAX inches, only one of the X, Y, or Z coordinates may reach its full scale value. Once a full scale value is reached, the positional coordinates no longer reflect the correct position of the sensor.

To convert the numbers into inches first cast it into a signed integer. This will give you a number from +/- 32767. Second multiply by 36 or 72 if using a standard range transmitter or 144 if using a extended range transmitter. Finally divide the number by 32767 to get the position in inches. The equation should look something like this:

Standard Range Transmitter: $(\text{signed int}(\text{Hex \#}) * 36) / 32767$

Standard Range Transmitter: $(\text{signed int}(\text{Hex \#}) * 72) / 32767$

Extended Range Transmitter: $(\text{signed int}(\text{Hex \#}) * 144) / 32767$

POSITION/ANGLES

POSITION/ANGLES

BINARY	ASCII	HEX	DECIMAL
Command Byte 01011001	Y	59	89

In the POSITION/ANGLES mode, the outputs from the POSITION and ANGLES modes are combined into one record containing the following twelve bytes:

MSB								LSB		
7	6	5	4	3	2	1	0	BYTE #		
1	X8	X7	X6	X5	X4	X3	X2	#1	LSbyte	X
0	X15	X14	X13	X12	X11	X10	X9	#2	MSbyte	X
0	Y8	Y7	Y6	Y5	Y4	Y3	Y2	#3	LSbyte	Y
0	Y15	Y14	Y13	Y12	Y11	Y10	Y9	#4	MSbyte	Y
0	Z8	Z7	Z6	Z5	Z4	Z3	Z2	#5	LSbyte	Z
0	Z15	Z14	Z13	Z12	Z11	Z10	Z9	#6	MSbyte	Z
0	Z8	Z7	Z6	Z5	Z4	Z3	Z2	#7	LSbyte	Zang
0	Z15	Z14	Z13	Z12	Z11	Z10	Z9	#8	MSbyte	Zang
0	Y8	Y7	Y6	Y5	Y4	Y3	Y2	#9	LSbyte	Yang
0	Y15	Y14	Y13	Y12	Y11	Y10	Y9	#10	MSbyte	Yang
0	X8	X7	X6	X5	X4	X3	X2	#11	LSbyte	Xang
0	X15	X14	X13	X12	X11	X10	X9	#12	MSbyte	Xang

See POSITION mode and ANGLE mode for number ranges and scaling.

POSITION/MATRIX

POSITION/MATRIX

BINARY	ASCII	HEX	DECIMAL
Command Byte 01011010	Z	5A	90

In the POSITION/MATRIX mode, the outputs from the POSITION and MATRIX modes are combined into one record containing the following twenty four bytes:

MSB	7	6	5	4	3	2	1	LSB	0	BYTE #
	1	X8	X7	X6	X5	X4	X3	X2		#1 LSbyte X
	0	X15	X14	X13	X12	X11	X10	X9		#2 MSbyte X
	0	Y8	Y7	Y6	Y5	Y4	Y3	Y2		#3 LSbyte Y
	0	Y15	Y14	Y13	Y12	Y11	Y10	Y9		#4 MSbyte Y
	0	Z8	Z7	Z6	Z5	Z4	Z3	Z2		#5 LSbyte Z
	0	Z15	Z14	Z13	Z12	Z11	Z10	Z9		#6 MSbyte Z
	0	M8	M7	M6	M5	M4	M3	M2		#7 LSbyte M(1,1)
	0	M15	M14	M13	M12	M11	M10	M9		#8 MSbyte M(1,1)
	0	M8	M7	M6	M5	M4	M3	M2		#9 LSbyte M(2,1)
	0	M15	M14	M13	M12	M11	M10	M9		#10 MSbyte M(2,1)
	0	M8	M7	M6	M5	M4	M3	M2		#11 LSbyte M(3,1)
	0	M15	M14	M13	M12	M11	M10	M9		#12 MSbyte M(3,1)
	0	M8	M7	M6	M5	M4	M3	M2		#13 LSbyte M(1,2)
	0	M15	M14	M13	M12	M11	M10	M9		#14 MSbyte M(1,2)
	0	M8	M7	M6	M5	M4	M3	M2		#15 LSbyte M(2,2)
	0	M15	M14	M13	M12	M11	M10	M9		#16 MSbyte M(2,2)
	0	M8	M7	M6	M5	M4	M3	M2		#17 LSbyte M(3,2)
	0	M15	M14	M13	M12	M11	M10	M9		#18 MSbyte M(3,2)
	0	M8	M7	M6	M5	M4	M3	M2		#19 LSbyte M(1,3)
	0	M15	M14	M13	M12	M11	M10	M9		#20 MSbyte M(1,3)

0	M8	M7	M6	M5	M4	M3	M2	#21	LSbyte	M(2,3)
0	M15	M14	M13	M12	M11	M10	M9	#22	MSbyte	M(2,3)
0	M8	M7	M6	M5	M4	M3	M2	#23	LSbyte	M(3,3)
0	M15	M14	M13	M12	M11	M10	M9	#24	MSbyte	M(3,3)

See POSITION mode and MATRIX mode for number ranges and scaling.

POSITION/QUATERNION

POSITION/QUATERNION

BINARY	ASCII	HEX	DECIMAL
Command Byte 01011101]	5D	93

In the POSITION/QUATERNION mode, The Bird outputs the X, Y, and Z position and the four quaternion parameters, q_0 , q_1 , q_2 , and q_3 which describe the orientation of the sensor with respect to the transmitter. The output record is in the following format for the fourteen transmitted bytes:

MSB	7	6	5	4	3	2	1	LSB	0	BYTE #
	1	X8	X7	X6	X5	X4	X3	X2		#1 LSbyte X
	0	X15	X14	X13	X12	X11	X10	X9		#2 MSbyte X
	0	Y8	Y7	Y6	Y5	Y4	Y3	Y2		#3 LSbyte Y
	0	Y15	Y14	Y13	Y12	Y11	Y10	Y9		#4 MSbyte Y
	0	Z8	Z7	Z6	Z5	Z4	Z3	Z2		#5 LSbyte Z
	0	Z15	Z14	Z13	Z12	Z11	Z10	Z9		#6 MSbyte Z
	0	B8	B7	B6	B5	B4	B3	B2		#7 LSbyte q_0
	0	B15	B14	B13	B12	B11	B10	B9		#8 MSbyte q_0
	0	B8	B7	B6	B5	B4	B3	B2		#9 LSbyte q_1
	0	B15	B14	B13	B12	B11	B10	B9		#10 MSbyte q_1
	0	B8	B7	B6	B5	B4	B3	B2		#11 LSbyte q_2
	0	B15	B14	B13	B12	B11	B10	B9		#12 MSbyte q_2
	0	B8	B7	B6	B5	B4	B3	B2		#13 LSbyte q_3
	0	B15	B14	B13	B12	B11	B10	B9		#14 MSbyte q_3

See POSITION mode and QUATERNION mode for number ranges and scaling.

QUATERNION

QUATERNION

	ASCII	HEX	DECIMAL
BINARY			
Command Byte	\	5C	92
01011100			

In the QUATERNION mode, The Bird outputs the four quaternion parameters that describe the orientation of the sensor with respect to the transmitter. The quaternions, q_0 , q_1 , q_2 , and q_3 where q_0 is the scaler component, have been extracted from the MATRIX output using the algorithm described in "Quaternion from Rotation Matrix" by Stanley W. Shepperd, Journal of Guidance and Control, Vol. 1, May-June 1978, pp. 223-4. The output record is in the following format for the eight transmitted bytes:

	MSB							LSB	
	7	6	5	4	3	2	1	0	BYTE #
1	B8	B7	B6	B5	B4	B3	B2		#1 LSbyte q_0
0	B15	B14	B13	B12	B11	B10	B9		#2 MSbyte q_0
0	B8	B7	B6	B5	B4	B3	B2		#3 LSbyte q_1
0	B15	B14	B13	B12	B11	B10	B9		#4 MSbyte q_1
0	B8	B7	B6	B5	B4	B3	B2		#5 LSbyte q_2
0	B15	B14	B13	B12	B11	B10	B9		#6 MSbyte q_2
0	B8	B7	B6	B5	B4	B3	B2		#7 LSbyte q_3
0	B15	B14	B13	B12	B11	B10	B9		#8 MSbyte q_3

Scaling of the quaternions is full scale = +.99996 = 7FFF Hex, 0 = 0 Hex, and -1.0 = 8000 Hex.

REFERENCE FRAME1**REFERENCE FRAME1**

	ASCII	HEX	DECIMAL
BINARY			
Command Byte 01001000	H	48	72

Command Data	Sin(A)	Cos(A)	Sin(E)	Cos(E)	Sin(R)	Cos(R)
--------------	--------	--------	--------	--------	--------	--------

By default, The Bird's reference frame is defined by the transmitter's physical X, Y, and Z axes. In some applications, it may be desirable to have the orientation measured with respect to another reference frame. The REFERENCE FRAME command permits you to define a new reference frame by inputting the angles required to align the physical axes of the transmitter to the X, Y, and Z axes of the new reference frame. The alignment angles are defined as rotations about the Z, Y, and X axes of the transmitter. These angles are called the, Azimuth, Elevation, and Roll angles.

The command sequence consists of a Command Byte and 12 Command Data bytes. The Command Data consists of the sines and cosines of the alignment angles Azimuth (A), Elevation (E), and Roll (R). See the REFERENCE FRAME2 command if you want to send only the angles and not the sines and cosines of the angles.

Although the REFERENCE FRAME1 command will cause The Bird's output angles to change, it has no effect on the position outputs. If you want The Bird's XYZ position reference frame to also change with this command then you must first use the EXAMINE/CHANGE VALUE XYZ REFERENCE FRAME command.

If you immediately follow the REFERENCE FRAME1 command with a POINT or STREAM mode data request you may not see the effect of this command in the data returned. It will take at least one measurement period (i.e. 10 milliseconds if running The Bird at 100 measurements/sec) before you see the effect of the command.

If the command is sent to the Master, then all accessible Birds in the Flock are updated.
If the command is sent to the Slave, then only the Slave is updated.

The Command Byte and Command Data must be transmitted to The Bird in the following thirteen-byte format:

MSB								LSB	
7	6	5	4	3	2	1	0	BYTE #	
0	1	0	0	1	0	1	0	#1 Command Byte	
B7	B6	B5	B4	B3	B2	B1	B0	#2 LSbyte SIN(A)	
B15	B14	B13	B12	B11	B10	B9	B8	#3 MSbyte SIN(A)	
B7	B6	B5	B4	B3	B2	B1	B0	#4 LSbyte COS(A)	
B15	B14	B13	B12	B11	B10	B9	B8	#5 MSbyte COS(A)	
B7	B6	B5	B4	B3	B2	B1	B0	#6 LSbyte SIN(E)	
B15	B14	B13	B12	B11	B10	B9	B8	#7 MSbyte SIN(E)	
B7	B6	B5	B4	B3	B2	B1	B0	#8 LSbyte COS(E)	
B15	B14	B13	B12	B11	B10	B9	B8	#9 MSbyte COS(E)	
B7	B6	B5	B4	B3	B2	B1	B0	#10 LSbyte SIN(R)	
B15	B14	B13	B12	B11	B10	B9	B8	#11 MSbyte SIN(R)	
B7	B6	B5	B4	B3	B2	B1	B0	#12 LSbyte COS(R)	
B15	B14	B13	B12	B11	B10	B9	B8	#13 MSbyte COS(R)	

The sine and cosine elements take values between the binary equivalents of +.99996 and -1.0.

Element scaling is +.99996 = 7FFF Hex, 0 = 0 Hex, and -1.0 = 8000 Hex.

REFERENCE FRAME2

REFERENCE FRAME2

	ASCII	HEX	DECIMAL
BINARY			
Command Byte 01110010	r	72	114

Command Data	A, E, R
--------------	---------

Same as the REFERENCE FRAME1 command except that the command data consists of the angles only and not the sines and cosines of the angles.

The Command Byte and Command Data must be transmitted to The Bird in the following seven-byte format:

MSB								LSB	
7	6	5	4	3	2	1	0	BYTE #	
0	1	1	1	0	0	1	0	#1 Command Byte	
B7	B6	B5	B4	B3	B2	B1	B0	#2 LSbyte A	
B15	B14	B13	B12	B11	B10	B9	B8	#3 MSbyte A	
B7	B6	B5	B4	B3	B2	B1	B0	#4 LSbyte E	
B15	B14	B13	B12	B11	B10	B9	B8	#5 MSbyte E	
B7	B6	B5	B4	B3	B2	B1	B0	#6 LSbyte R	
B15	B14	B13	B12	B11	B10	B9	B8	#7 MSbyte R	

See the ANGLES command for the format and scaling of the angle values sent.

REPORT RATE**REPORT RATE**

Measurement BINARY Rate Divisor Command	ASCII	HEX	DECIMAL
1 01010001	Q	51	81
2 01010010	R	52	82
8 01010011	S	53	83
32 01010100	T	54	84

If you do not want a Bird data record output to your host computer every Bird measurement cycle when in STREAM mode then use the REPORT RATE command to change the output rate to every other cycle (R), every eight cycles (S) or every thirty-two cycles (T). If no REPORT RATE command is issued, transmission proceeds at the measurement rate by default.

RS232 TO FBB**RS232 TO FBB**

	HEX	DECIMAL	BINARY
	(Normal/Expanded/Super-Expanded Addressing mode)		
Command Byte	F0/E0/A0	240/224/160	11110000/11100000/10100000 + FBB ADDR

The RS232 TO FBB pass through command allows the host computer to communicate with any specified Birds in the Flock via a single RS232 interface. The command can ONLY be used when communicating with the Master Bird. The command is a preface to each of the RS232 commands. When in Normal or Expanded Addressing mode the RS232 TO FBB command is 1 Byte long. When in Super-Expanded Addressing mode the command is 2 Bytes long.

For the Normal Addressing mode (addresses 1 to 15) the command looks like:

Command Byte = F0 + destination FBB address in Hex

(i.e. FBB address 1 (1 Hex) would be F1
FBB address 14 (E Hex) would be FE)

For the Expanded Addressing mode (addresses 1 to 30) the command looks like:

Addresses 1 to 15:

Command Byte = F0 + destination FBB address in Hex

(i.e. FBB address 1 (1 Hex) would be F1
FBB address 15 (F Hex) would be FF)

Addresses 16 to 30:

Command Byte = E0 + destination FBB address in Hex - 10 Hex

(i.e. FBB address 16 (10 Hex) would be E0
FBB address 30 (1E Hex) would be EE)

For the Super-Expanded Addressing mode (addresses 1 to 126) the command looks like:

Command Byte 1 = A0

Command Byte 2 = destination FBB address in Hex

Example 1: There are two Birds in the Flock in the Normal Addressing mode. One at FBB address 1 and the other at FBB address 2, configured for the 1 transmitter/2 sensor Mode. By default The Bird at address 1 is the Master and The Bird at address 2 is the Slave. The host's RS232 interface is connected to The Bird at address 1. The jumpers in Bird 1 are configured for RS232 communications while the jumpers in Bird 2 can be configured for either RS232 or FBB communications.

To get Position/Angle data from Bird 1, the host would either send:

- a 2 byte command consisting of: the RS232 TO FBB command, F1 (Hex), followed by the POINT command, 42 (Hex)
- or the 1 byte POINT command 42 (Hex)

To get Position/Angle data from Bird 2, the host would send:

- a 2 byte command consisting of: the RS232 TO FBB command, F2 (Hex), followed by the POINT command, 42 (Hex)

Example 2: There are two Birds in the Flock in the Super-Expanded Addressing mode. One at FBB address 1 and the other at FBB address 2, configured for the 1 transmitter/2 sensor Mode. By default The Bird at address 1 is the Master and The Bird at address 2 is the Slave. The host's RS232 interface is connected to The Bird at address 1. The jumpers in Bird 1 are configured for RS232 communications while the jumpers in Bird 2 can be configured for either RS232 or FBB communications.

To get Position/Angle data from Bird 1, the host would either send:

- a 3 byte command consisting of: the RS232 TO FBB command, A0 (Hex), the destination FBB address in Hex (01), and the POINT command, 42 (Hex)
- or the 1 byte POINT command 42 (Hex)

To get Position/Angle data from Bird 2, the host would send:

- a 3 byte command consisting of: the RS232 TO FBB command, A0 (Hex), the destination FBB address in Hex (02), and the POINT command, 42 (Hex)

Notes:

- 1) To use STREAM mode with multiple Birds, first send the GROUP MODE command to the Master before sending the STREAM command to the Master.

- 2) Data output from the Master may be delayed up to 2 milliseconds (when running at 100 measurements/second) from the time the RS232 TO FBB command is issued.

RUN**RUN**

	ASCII	HEX	DECIMAL
BINARY			
Command Byte 01000110	F	46	70

The RUN command is issued to the Master Bird, but not to the Slave Bird, to start The Flock of Birds FLYing or to the standalone Bird to restart normal system operation after The Bird has been put to sleep with the SLEEP command. RUN does not reinitialize the system RAM memory, so any configuration or alignment data entered before the system went to SLEEP will be retained.

SLEEP**SLEEP**

	ASCII	HEX	DECIMAL
BINARY			
Command Byte 01000111	G	47	71

The SLEEP command turns the transmitter off and halts the system. The command is issued to the Master Bird or the standalone Bird but not to the Slave Bird. While asleep, The Bird will respond to data requests and mode changes but the data output will not change. To resume normal system operation, issue the RUN command.

STREAM**STREAM**

	ASCII	HEX	DECIMAL
BINARY			
Command Byte	@	40	64
01000000			

In the STREAM mode, The Bird starts sending continuous data records to the host computer as soon as the @ Command Byte is received. Data records will continue to be sent until the host sends the POINT command or any format command such as POSITION to stop the stream.

The STREAM command can be used with either a Bird in stand alone mode or with a group of Birds with a single FBB or RS232 interface. If you are using a group of Birds with a single FBB or RS232 interface you must first enable the GROUP MODE. Remember that when the GROUP MODE is enabled an extra byte containing the FBB address of The Bird is added to the end of each data record.

Some computers and/or high level software languages may not be able to keep up with the constant STREAM of data in this mode. Bytes received by your RS232 port may overrun one another or your input buffer may overflow if Bird data is not retrieved fast enough. This condition will cause lost bytes, hence if your high level application software requests say 12 bytes from the RS232 input buffer, it may hang because one or more bytes were lost. To eliminate this possibility, read one byte at a time looking for the phasing bit that marks the first byte of the data record.

See REPORT RATE to change the rate at which records are transmitted during STREAM.

SYNC

SYNC

	ASCII	HEX	DECIMAL
BINARY			
Command Byte	A	41	65
01000001			

Command Data	SYNCtype

The SYNC command must be issued to The Bird in the following 2-byte sequence:

MSB								LSB	
7	6	5	4	3	2	1	0	BYTE #	
0	1	0	0	0	0	0	1	#1 Command Byte	
D7	D6	D5	D4	D3	D2	D1	D0	#2 Command Data	

- Where D7-D0
- = 00000000 for no sync
 - = 00000001 for CRTSYNC type 1
 - = 00000010 for CRTSYNC type 2
 - = 00001000 for HOSTSYNC type 1
 - = 11111111 for CRTSYNC type 255, pickup placement

The Flock of Birds offers several methods of synchronizing its operation and outputs to external events. All user supplied synchronization signals and requests must be directed to the current Master Bird or to a standalone unit.

CRTSYNC Modes

If you are using the sensor or three-button mouse within a few feet of a magnetically deflected cathode ray tube, The Bird's outputs may become noisy. Use the SYNC command in conjunction with the CRT sync cable shipped with your unit to eliminate this

noise. The CRT sync pickup must be plugged into The Bird's SYNC connector located on its back panel before you execute any of the SYNC (CRT Mode) commands. Instructions for installing the CRT sync cable can be found in Section 2.2.6.

The single Command Data byte, SYNCtype, that you send with the SYNC command controls the operation of The Bird with respect to your CRT's vertical scan. Set SYNCtype = 0 (system power-up default) if you do not want The Bird to be synchronized to either the operation of your CRT or the host computer. Set SYNCtype = 1 to synchronize The Bird to your CRT if your CRT has an unusually high vertical retrace rate, that is, greater than 72 cps but less than 144 cps. When SYNCtype is 1, The Bird makes measurements at the sync rate. For best performance SYNCtype should only be set to 1 if the sync rate is at least 100 cycles per second. Set SYNCtype = 2 to synchronize The Bird to your CRT if your CRT's vertical retrace rate is in the normal range of 50 to 72 cps. When SYNCtype is 2, The Bird makes measurements at twice this rate, that is, from 100 to 144 updates per second. Before you set SYNCtype = 1 or 2, you should use SYNCtype = 255 to determine your CRT's vertical retrace rate and to help you find the best spot on the outside of the CRT's housing for the sync pickup. Each time you send SYNCtype = 255, The Bird will return two words to aid you in finding the "sweet spot". The first word represents a voltage proportional to the strength of your CRT's vertical scan signal. Locate the pickup where this voltage will be at least 1 volt or more. The maximum voltage reading will be obtained on the top or side of your CRT's housing near the deflection yoke. The deflection yoke is typically located about halfway between the front and back of the cabinet. The second word represents the scan rate of your CRT. If you get a voltage reading but the scan rate number remains zero, it means that your CRT's vertical scan rate is less than 31 cps. The Bird will not synchronize to a CRT at these lower rates. When you set SYNCtype = 255, the front panel light will go out to remind you that The Bird is not running normally. You must set SYNCtype NOT equal to 255 before The Bird will start running again.

The two words returned each time you issue the command with the Command Data = 255 are formatted per the following four bytes, with no phasing bits employed:

MSB							LSB	
7	6	5	4	3	2	1	0	BYTE #
B7	B6	B5	B4	B3	B2	B1	B0	#1 LSbyte scan voltage
B15	B14	B13	B12	B11	B10	B9	B8	#2 MSbyte scan voltage

B7	B6	B5	B4	B3	B2	B1	B0	#3	LSbyte scan rate
B15	B14	B13	B12	B11	B10	B9	B8	#4	MSbyte scan rate

The scan voltage will return values between 7FFF and 8000 Hex. Element scaling is 7FFF Hex = 4.99 volts, 0 = 0 Hex = 0 volts and 8000 Hex = -5.0 volts.

The scan rate measurement will return timer COUNTS between 0 and FFFF Hex. After converting COUNTS to an integer between 0 and 65535, the scan rate is computed from:

$$\text{scan rate in hertz} = 500,000 / (\text{CLOCK} * \text{COUNTS})$$

where CLOCK is the period of one computer time count in microseconds. With a crystal value equal to 25 MHz, CLOCK = 8/25. With a 32 MHz crystal, CLOCK = 8/32. The crystal value is determined by using the command EXAMINE VALUE BIRD COMPUTER CRYSTAL SPEED.

HOSTSYNC Mode

When SYNCtype = 8 The Bird is in host sync mode. In this mode The Bird starts a measurement cycle only when the RS232 command POINT or STREAM or the FBB SEND DATA command is received from your host computer. In addition to starting a measurement cycle, The Bird starts outputting the most recent position and orientation data record. The data output is approximately 5 milliseconds old when it starts coming out. When the STREAM command is received, the next measurement cycle starts immediately but the output of the data record is delayed for approximately 5 milliseconds while it is being computed. Issue the STREAM command every cycle to obtain data records that are zero milliseconds old. An important note to this command is that the user must issue the POINT or STREAM or FBB SEND DATA commands at a regular rate with a frequency of 100 Hz to 144 Hz. If you just issue the POINT or STREAM or FBB SEND DATA commands every now and then when SYNCtype = 8 is in force, the resulting position and orientation data returned will be greatly in error. When operating with a Flock of Birds using the FBB or a single RS232 interface to talk to all Flock members, only the Master outputs its data on receipt of the FBB SEND DATA, or POINT command. The host must individually request data from the Slaves.

If your host is going to send data requests at a rate greater than The Bird's default

measurement rate of approximately 100 measurements/sec then you must first utilize the CHANGE VALUE BIRD MEASUREMENT RATE command to set The Bird to a rate that is slightly faster than the host's fastest rate (i.e. if the host's rate is 120 measurements/sec set The Bird to 123 measurements/sec).

Since The Bird is ready to output position and orientation data about 6 milliseconds before it is able to start a new measurement cycle, you should use the CHANGE VALUE DISABLE/ENABLE DATA READY mode instead of the HOSTSYNC mode if you want to minimize data lag.

XOFF**XOFF**

	ASCII	HEX	DECIMAL
BINARY			
Command Byte 00010011	DC3	13	19

The Bird responds to the XON/XOFF commands which many computers use for RS-232C flow control. When your host computer sends The Bird an XOFF, the unit will halt transmission at the end of the current output record. It will not halt transmission at the instant it receives the command. If you need to halt the flow instantly, use the RS-232C DATA TERMINAL READY SIGNAL that your host computer's UART sends over the RS-232C cable to The Bird. The XOFF command cannot be sent to The Bird mixed in with the Command Data of another command, as it simply will be interpreted by The Bird as Command Data.

XON**XON**

	ASCII	HEX	DECIMAL
BINARY			
Command Byte 00010001	DC1	11	17

The Bird responds to the XON/XOFF commands which many computers use for RS-232C flow control. When your host system sends The Bird an XON, the unit will resume transmission of any data records that were pending when it was XOFFed (see XOFF). The XON command cannot be sent to The Bird mixed in with the Command Data of another command, as it simply will be interpreted by The Bird as Command Data.

10.0 ERROR MESSAGES

The Bird keeps track of system errors. These errors are reported via the panel lights and the SYSTEM ERROR register. When an error occurs, the SYSTEM STATUS register ERROR bit is set to a '1', and the error code is put into the SYSTEM ERROR register. The user can query the SYSTEM ERROR register with the RS232 command, EXAMINE VALUE/SYSTEM ERROR or the FBB command FBB SEND ERROR CODE. When the user reads SYSTEM STATUS, the ERROR bit is reset to a '0' and when the user reads the SYSTEM ERROR register, all bits are reset to '0'. In addition to updating the SYSTEM ERROR register, the panel light will temporarily or permanently stop The Bird and blink the error code as 10 short blinks followed by the N long blinks, where N is the error code. The stopping of The Bird and blinking during an error condition can be disabled using the CHANGE VALUE ERROR DETECT MASK command. Most error conditions can be cleared up by just reissuing the AUTO-CONFIGURATION command to the Master. Other error conditions will require you to cycle the power switch.

The error codes are summarized on the next page. A detailed description of each is presented later.

<u>CODE</u>	<u>ERROR DESCRIPTION</u>	<u>TYPE</u>
1	System Ram Failure	FATAL
2	Non-Volatile Storage Write Failure	FATAL
3	PCB Configuration Data Corrupt	WARNING1
4	Bird Transmitter Calibration Data Corrupt or Not Connected	WARNING1
5	Bird Sensor Calibration Data Corrupt or Not Connected	WARNING1
6	Invalid RS232 Command	WARNING2
7	Not an FBB Master	WARNING2
8	No Birds accessible in Device List	WARNING2
9	Bird is Not Initialized	WARNING2
10	FBB Serial Port Receive Error - Intra Bird Bus	WARNING1
11	RS232 Serial Port Receive Error	WARNING1
12	FBB Serial Port Receive Error - FBB Host Bus	WARNING1
13	No FBB Command Response	WARNING1
14	Invalid FBB Host Command	WARNING1
15	FBB Run Time Error	FATAL
16	Invalid CPU Speed	FATAL
17	No FBB Data	WARNING1
18	Illegal Baud Rate	WARNING1
19	Slave Acknowledge Error	WARNING1
20-27	Intel 80186 CPU Errors	FATAL
28	CRT Synchronization	WARNING1
29	Transmitter Not accessible	WARNING1
30	Extended Range Transmitter Not Attached	WARNING1
31	CPU Time Overflow	WARNING2
32	Sensor Saturated	WARNING1
33	Slave Configuration	WARNING1
34	Watch Dog Timer	WARNING1
35	Over Temperature	WARNING1

<u>MESSAGE TYPE</u>	<u>DESCRIPTION</u>
FATAL	Error is posted in system status, panel light continuously blinks the error code, the Flock stops running.
WARNING1	Error is posted in system status, panel light blinks the error code once, the Flock resumes operation after the blinking stops.
WARNING2	Error is posted in the system status, no light blinking, the Flock

continues to run.

10.1 ERROR MESSAGE DETAILS

For each of the Flock error codes a possible cause and corrective action are listed. Corrective actions with an * indicate that the user should not attempt this fix but rather Ascension Technology should be called.

<u>CODE</u>	<u>ERROR DESCRIPTION</u>	<u>TYPE</u>
1	RAM Failure Cause: System RAM Test has did not PASS. Action: *Check for shorts or opens to the RAM chips and if OK, replace system RAM.	FATAL
2	Non-Volatile Storage Write Failure Cause: Occurs when trying to write a transmitter, sensor, or PCB EEPROM but the device does not acknowledge either because it is not there or there is a circuit failure. Action: *Check the target EEPROM via a read command to verify that it is present prior to writing the device.	FATAL
3	PCB Configuration Data Corrupt Cause: The system was not able to read the PCB EEPROM 'Initialized Code'. Action: *Verify that the error persists after removing the transmitter and the sensor.	WARNING1
4	Transmitter Configuration Data Corrupt Cause: The system was not able to read the Transmitter EEPROM 'Initialized Code' or the Transmitter is not plugged in. Action: *Insure that the Transmitter is present, calibrate the transmitter and set the 'Initialized Code' in the EEPROM.	WARNING1
5	Sensor Configuration Data Corrupt Cause: The system was not able to read the Sensor EEPROM 'Initialized Code' or the Sensor is not plugged in. Action: *Insure that the Sensor is present, calibrate the sensor and set the 'Initialized Code' in the EEPROM.	WARNING1
6	Invalid RS232 Command Cause: The system has received an invalid RS232 command, which can occur if the user sends down a command character that is not defined or if the data for a command does make sense (i.e., change value commands with an unknown parameter number). Action: Only send valid RS232 commands to The Bird.	WARNING2
7	Not an FBB Master Cause: The system received a command which should only be sent to the Master Bird. Action: Send the command with the address of the Master. As a note, commands which should only be sent to the Master Bird can be sent to the BROADCAST address.	WARNING2

<u>CODE</u>	<u>ERROR DESCRIPTION</u>	<u>TYPE</u>
8	<p>No Birds accessible in Device List</p> <p>Cause: The Master Bird detects that no Birds are accessible in the FBB Devices word part of the FBB Configuration Command.</p> <p>Action: All accessible Birds must be indicated in the FBB Devices part of the FBB Configuration Command.</p>	WARNING2
9	<p>Bird is Not Initialized</p> <p>Cause: The Master Bird is sent the FBB ARM command but it has not been initialized via the FBB Configuration command.</p> <p>Action: Send the FBB Configuration command prior to sending the FBB ARM or the WAKE UP command.</p>	WARNING2
10	<p>FBB Receive Error - Intra Bird Bus</p> <p>Cause: Either an overrun or framing error has been detected by the serial channel 0 UART as it received characters from another Bird on the internal RS485 interface.</p> <p>Action: If all Birds have the proper crystal installed then this error should never occur.</p>	WARNING1
11	<p>RS232 Receive Overrun or Framing Error</p> <p>Cause: An overrun or framing error has been detected by the serial channel 1 UART as it received characters from the user's host computer on the RS232 interface.</p> <p>Action: If an overrun error, the baud rate of the user's host computer and The Bird differ. This may be due to incorrect baud selection, inaccuracy of the baud rate generator, or the RS232 cable is too long for the selected baud rate. If a framing error, the host software may be sending characters to its own UART before the UART finishes outputting the previous character.</p>	WARNING1
12	<p>FBB Receive Error - FBB Host Bus</p> <p>Cause: Either an overrun or framing error has been detected by the serial channel 1 UART as it received characters from the user's host computer on the RS485 interface.</p> <p>Action: If an overrun error, the baud rate of the user's host computer and The Bird differ. This may be due to incorrect baud selection or inaccuracy of the baud rate generator. If a framing error, the host software may be sending characters to its own UART before the UART finishes outputting the previous character.</p>	WARNING1
13	<p>No FBB Command Response</p> <p>Cause: The Master Bird has sent a command to a Slave Bird that required a response, but the Slave never responded.</p> <p>Action: Check that the Slave Birds are attached. Check FBB cabling. Check that Slave Bird addresses match the FBB Configuration.</p>	WARNING1

<u>CODE</u>	<u>ERROR DESCRIPTION</u>	<u>TYPE</u>
14	Invalid FBB Host Command Cause: The Flock has received an invalid FBB host command which can occur if the user sends down a command character to the proper device address but the command is invalid. Action: Only send valid FBB commands to The Bird when in FBB Host control mode.	WARNING1
15	FBB Run Time Error Cause: Not currently used. Action: Should never occur.	FATAL
16	Invalid CPU Speed Cause: If the system reads an invalid CPU speed from the system EEPROM and the EEPROM is initialized the error will occur. Action: *Initialize the system EEPROM.	FATAL
17	No Data Error Cause: When a Slave is expecting data from the Master and does not receive data this error will occur. Action: This error should not occur.	WARNING1
18	Illegal Baud Rate Error Cause: If the dipswitch is in an 'invalid' baud rate setting then this error will occur. Action: Set dipswitch to a valid baud rate setting.	WARNING1
19	Slave Acknowledge Error Cause: This error will occur if the Master sends a multibyte command to a Slave and the Slave does not respond. For example, if the user sends the Master the Auto-Configuration Command with 2 Flock units, and Bird at address #2 is not connected to the FBB or not in FLY mode then during the ARMing process the Master will display this error. Action: Assure that the FOB configuration is correct, all units are attached to the FBB and at the proper address and that all units are in FLY mode.	WARNING1
20	Unused_INT4 Cause: CPU overflow. Action: *Check code for INTO instruction.	FATAL
21	Unused_INT5 Cause: Array Bounds. Action: *Check code for BOUND Instruction.	FATAL
22	Unused_INT6 Cause: Unused Opcode. Action: *CPU has executed an invalid opcode. Possibly bad (or going bad) EPROM. Also, check the power supply to assure that the +5VD is not dropping below 4.75 volts even when the transmitter is running.	FATAL

<u>CODE</u>	<u>ERROR DESCRIPTION</u>	<u>TYPE</u>
23	Unused_INT7 Cause: ESC Opcode. Action: *Check code for the ESC Instruction.	FATAL
24	Unused_INT9 Cause: Reserved. Action: *Should never occur.	FATAL
25	Unused_INT10 Cause: Reserved. Action: *Should never occur.	FATAL
26	Unused_INT11 Cause: Reserved. Action: *Should never occur.	FATAL
27	Unused_INT16 Cause: Numeric coprocessor exception. Action: *Numeric CPU does not exist so this should never occur. Check to make sure the ERROR/signal on the CPU is tied to +5VD.	FATAL
28	CRT Synchronization Error Cause: When in CRT Synchronization mode, if the CRT synchronization signal is not present then this error will occur. Action: Assure that the synchronization signal is present using the Display CRT Synchronization Information command.	WARNING1
29	Transmitter Not accessible Error Cause: This error occurs when the host starts the system FLYing via the Auto-Configuration command, and a Bird which should have a transmitter, does not have a transmitter. Action: Assure that the specified Bird has a transmitter.	WARNING1
30	Extended Range Transmitter Not Attached Error Cause: If the Extended Range Controller does not have an Extended Range Transmitter attached then this error will occur. Action: Assure that the Extended Range Controller has a Extended Range Transmitter attached.	WARNING1
31	CPU Time Overflow Error Cause: This error occurs if the CPU in The Bird or Extended Range Controller runs out of CPU time. This can occur if the host overburdens The Bird with multiple commands in a measurement cycle. Action: The host can either slow down the measurement rate or decrease the number of commands sent to The Bird.	WARNING2

<u>CODE</u>	<u>ERROR DESCRIPTION</u>	<u>TYPE</u>
32	<p>Sensor Saturated Error</p> <p>Cause: This error occurs if the sensor is saturated during power-up. This will occur if the sensor is not connected, the sensor or cable is damaged, a large magnetic field is present, or the sensor is sitting on a steel table.</p> <p>Action: The User should check that the sensor is attached to The Bird (screw in the connector) and that none of the other above mentioned conditions exist.</p>	WARNING1
33	<p>Slave Configuration Error</p> <p>Cause: This error occurs if the Master determines that a Slave is not configured with a sensor during the Auto-Configuration or Arming command.</p> <p>Action: Verify that all the Slaves have their sensors attached.</p>	WARNING1
34	<p>Watch Dog Error</p> <p>Cause: This error occurs on an Extended Range Controller if the CPU does not update the Watch Dog Timer within a 100 mS period. This will only occur if the CPU or ROMs fail during operation.</p> <p>Action: *Should never occur.</p>	WARNING1
35	<p>Over Temperature Error</p> <p>Cause: This error occurs on an Extended Range Controller if the transmitter driver overheats. This can occur if the fan in the controller fails or if the ambient temperature of the controller exceeds operating specifications.</p> <p>Action: Verify that the fan is operating.</p>	WARNING1

11.0 GETTING IN AND OUT OF TROUBLE

Although The Bird is resistant to problems, there are a few ways you can get into trouble:

- 1) If the front panel LED blinks continuously, it means that you are in the test mode, and the system is not actually functioning. Check dipswitch #8. It should be in the OFF position (pointing up) for normal system operation.
- 2) If the front panel light does not come on at all: (a) verify that the power supply cable is plugged into the power supply and wall. The cable may appear to be plugged into the supply but may be loose. (b) disconnect the RS232 interface cable at The Bird's back panel and toggle the FLY/STDBY switch. If the light now comes on, it means that your RS232 interface cable has a wire attached to pin 7 of The Bird's RS232 connector and that your host computer is holding the Request to Send line high. Either disconnect the wire to pin 7 or reprogram your RS232 UART to deassert the RTS line.
- 3) If The Bird does not function or runs erratically make sure that all cables are screwed into their front and back panel connectors.
- 4) If you cannot get The Bird to communicate with your computer, try using The Bird Output test and The Bird Echo test to verify the host serial link. Verify that all Birds are either in the Normal Addressing mode, Expanded Addressing mode or Super-Expanded Addressing mode by counting the light blinks on powerup. Verify that you are using the correct baud rate switch setting for the address mode being used (Fig. 4 for Normal Addressing mode, Fig. 5 for Expanded Addressing mode. Super-Expanded Addressing mode only has the one baud rate of 115.2K).
- 5) If the serial communication is not working in RS232 mode, check if pin 4 of the serial port (Data Terminal Ready) is being held high. If your computer brings it low, The Bird will not send data. If in doubt, disconnect the pin at the cable where it connects to The Bird.
- 6) If you can not communicate with The Bird, check that the transmitter and sensor are plugged into their panel connectors. The transmitter and sensor must be plugged in during power-up.

-
- 7) If upon starting your software to control multiple Birds in the Flock, the light goes out or the data output does not correspond to reality verify that your software delays for at least 600 milliseconds before and after sending the Flock the FBB AUTO-CONFIGURATION, FBB ARM, or FBB CONFIGURATION commands.
 - 8) If you send Command Bytes without their proper Command Data bytes, the system may hang. Toggling the FLY/STDBY switch should return you to normal operation. (See note below.)
 - 9) If the position/orientation outputs from the system are noisy, be sure that the sensor is not located near The Bird's power supply or other electronic devices or cables.
 - 10) If one or more of the position outputs stops changing at longer separation distances use the CHANGE VALUE/POSITION SCALING command to change the full scale output from 36 to 72 inches. Your software will also need to change its output scaling to corresponded to The Birds change.
 - 11) If the signs of the X, Y or Z position outputs suddenly change you may have crossed a hemisphere boundary. Use the HEMISPHERE command to rectify.
 - 12) Once you have established proper communication with The Bird, any problems which cause it to hang can generally be corrected by toggling the FLY/STDBY switch. In some cases, you may have to restart your host computer.
 - 13) If the host seems to be missing data from The Bird, the host's operating system may be removing from The Bird's data stream some bytes that represent host system control commands. Verify that the host can read all binary characters from the serial port using the Host Read Data test and the Host Read Data Read Block test.
 - 14) If The Flock with the Extended Range Transmitter (ERT) option is returning fixed position data and zero orientation data then you are requesting data from the ERT which has no sensor. Use the RS232 TO FBB command to direct your data request to a Flock unit with a sensor.
 - 15) If you are in standalone mode and on powerup the light blinks twice then goes out, you are in the Expanded Addressing mode. Restore the Normal Addressing mode

by following the instructions in Section 8.8.

- 16) There are no fuse or other user-serviceable parts inside The Bird's cabinet. If the front-panel LED does not come on (or blink) when the RS232 cable is disconnected, then the unit is not getting power.

For technical assistance call Ascension Technology at 802-893-6657 between the hours of 9 AM and 5 PM Eastern Standard time or FAX us at 802-893-6659.

APPENDIX I - NOMENCLATURE

- FBB** Fast Bird Bus. A high baud rate RS485 interface interconnecting The Bird units. The FBB is used by The Birds for talking among themselves. The user host communicates using either RS-232C or RS485 interfaces. The RS485 interface is a separate half duplex bus within the FBB bus.
- FOB** Flock of Birds. A hardware configuration which ties several Bird units together via the FBB.
- MASTER** The Master Bird is the Flock Bird that is controlling and coordinating the operation of all other Flock Birds (the Slaves). The Master controls the sequencing and synchronizing of Flock transmitters and tells sensors when to measure the transmitted magnetic fields. The user's host computer communicates with the Master to start and stop the Flock and perform other major Flock control functions. There can only be one Master running on the FBB at a time. The Master Bird may have its own transmitter but this is not a requirement. The Flock can run using a transmitter attached to a Slave. All Birds in the Flock must have a sensor.
- SLAVE** One or more Birds in the Flock with a sensor and possibly a transmitter that receive operating instructions from the Master Bird. If the Slave unit has a transmitter, the user's host computer may tell the Master to turn on this Slave's transmitter via the NEXT TRANSMITTER command.
- STANDALONE** A single Bird unit with its own transmitter and sensor using the RS232 interface.

APPENDIX II - OPTIONAL POWER SUPPLY SPECIFICATIONS

The optional power supply is an AULT Inc. model SW300. This supply utilizes switching technology to provide 25 watts regulated output. Its specifications are:

Physical:

Dimensions:	148.5mm x 122mm x 48.6mm
Input connector:	for standard IEC 3-wire cord
Output connector:	9-pin D subminiature female

Electrical:

Power input:	100-250 VAC, 50/60 Hz, single phase
Total output power:	25 watts maximum
Output voltages/currents:	+5 VDC @ 4.0 amps maximum +12 VDC @ 1.0 amps maximum -12 VDC @ 0.6 amps maximum Total not to exceed 25 watts

Power cable connector pinout:

- 1 Remote Sense -
- 2 Remote Sense +
- 3 +5 VDC
- 4 +5 VDC
- 5 Common
- 6 Common
- 7 -12 VDC
- 8 +12 VDC
- 9 Earth Ground

Note if you provide your own power supply:

- 1) The supply should be UL listed with a maximum output voltage/current ratings that do not exceed the above listed values.
- 2) Never hook Common to Earth Ground. Degraded operation will result.
- 3) The cable wiring from your supply to The Bird should be at least AWG #18 gauge (preferably AWG #16) to minimize voltage drop across the cable.
- 4) The AULT supply does not have remote sensing. If your supply has remote sensing attach it to the above indicated pins.

APPENDIX III - BIRD SPECIFICATIONS

Physical:

Transmitter:	3.75-inch cube (mounted inside enclosure or external) with 10' cable.
Sensor:	1.0" x 1.0" x 0.8" cube (or optional 3-button mouse) with 10' or optional 25' cable
Enclosure:	9.5" x 11.5" x 2.6"

Technical:

Positional range:	± 48" in any direction
Angular range:	± 180° Azimuth & Roll ± 90° Elevation
Static positional accuracy:	0.1" RMS averaged over the translational range
Positional resolution:	0.03" @ 12"
Static angular accuracy:	0.5° RMS averaged over the translational range
Angular resolution:	0.1° RMS @ 12"
Update rate:	100 measurements/sec
Outputs:	X, Y, Z positional coordinates and orientation angles, rotation matrix, or quaternions
Interface:	RS232: 2,400 to 115,200 baud RS485: 57,600 to 500,000 baud
Format:	Binary
Modes:	Point or Stream (RS232 only)

Electrical:

Power requirements:	+5 VDC @ 2.45 amps avg., 3.85 amps peak +12 VDC @ 0.53 amps avg., 0.63 amps peak -12 VDC @ 0.34 amps avg., 0.46 amps peak
---------------------	---

Environment:	All specifications are valid at 30 deg C ± 10 deg in an environment void of large metal objects and electromagnetic frequencies, other than the power line.
---------------------	---

APPENDIX IV - JUMPER LOCATIONS ON THE BIRDS CIRCUIT BOARD

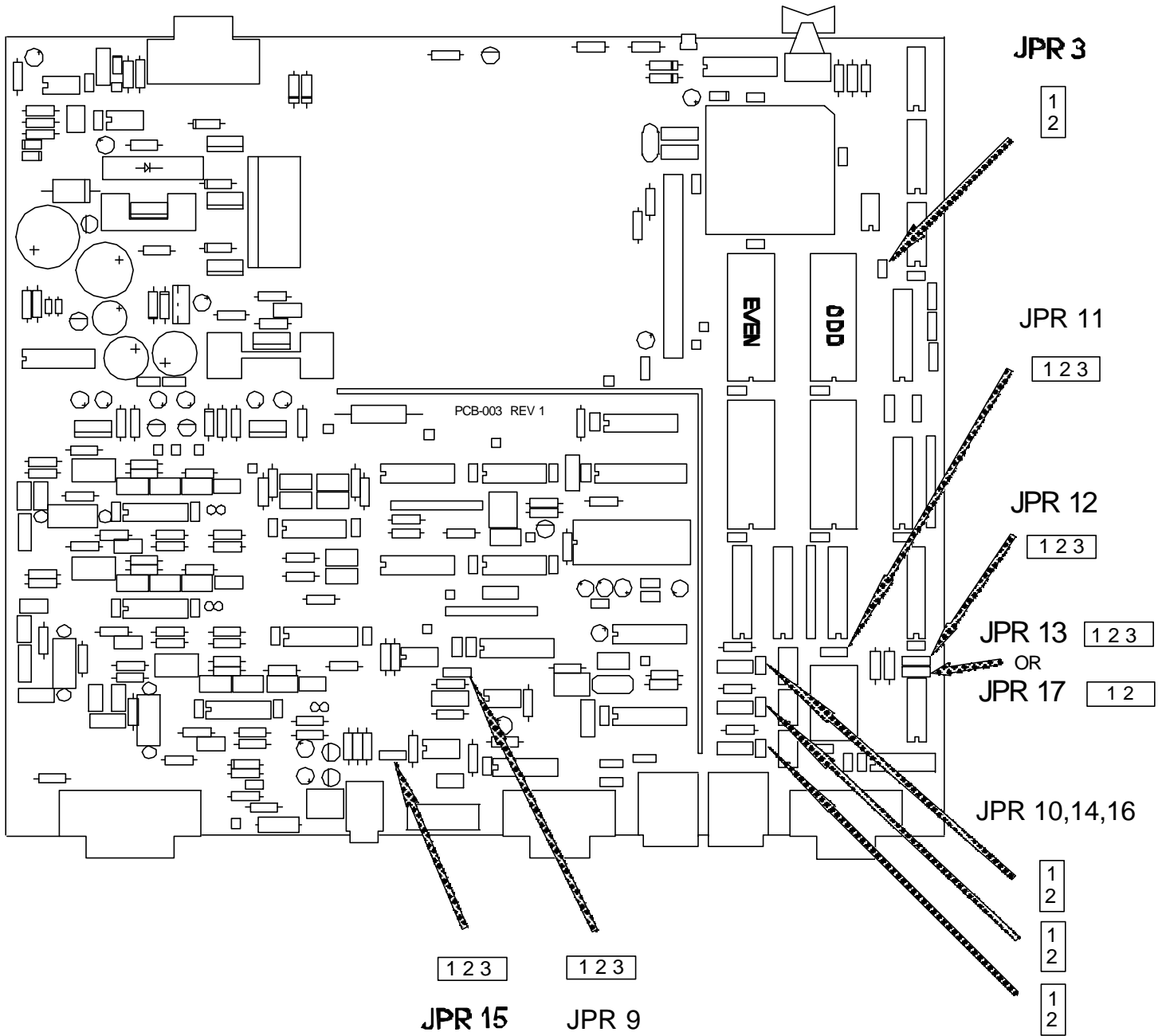

THE EXTENDED RANGE CONTROLLER CIRCUIT CARD JUMPER LOCATION

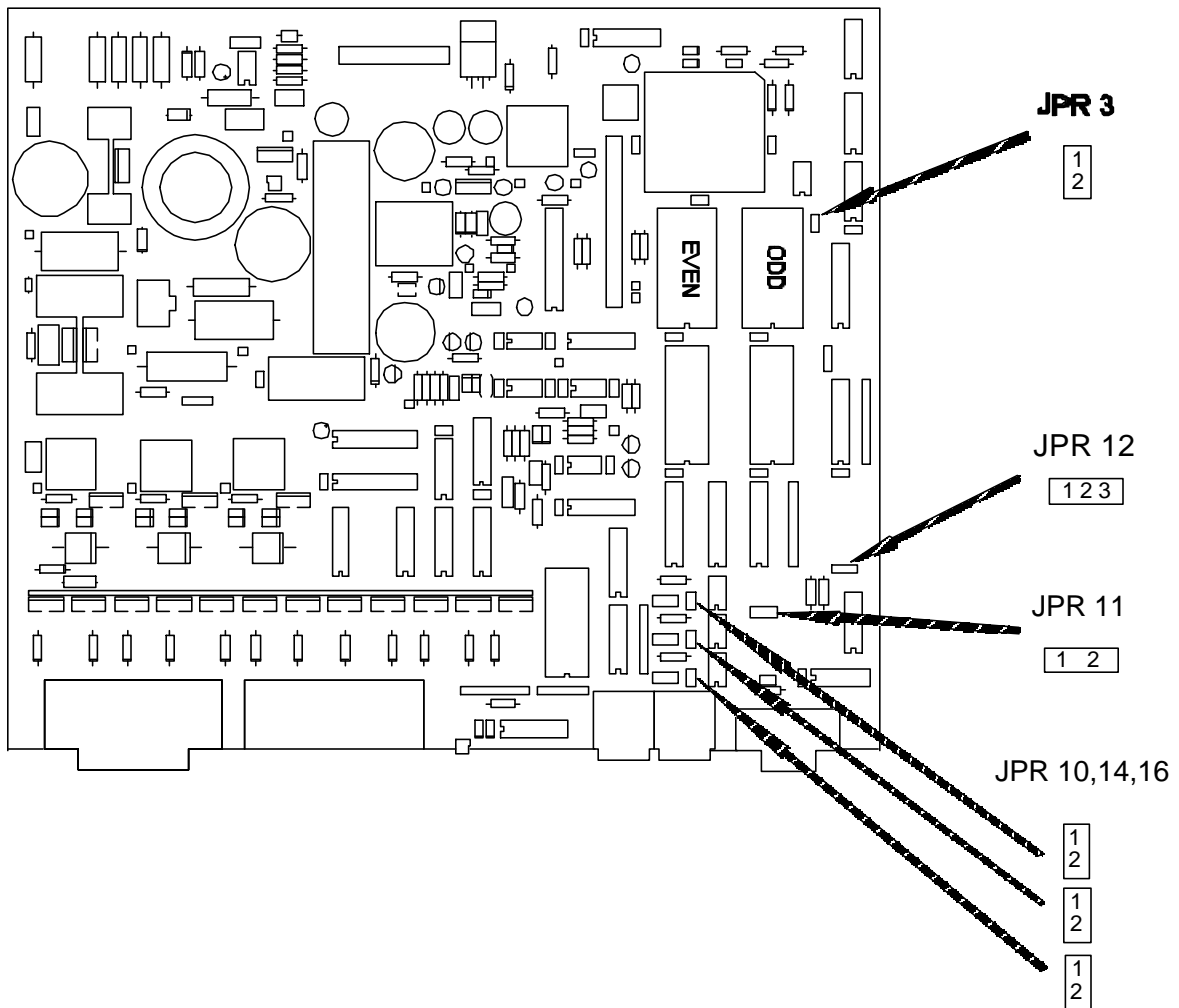

APPENDIX V - APPLICATION NOTES

Application Note #1

Compute The Coordinates of a Stylus Tip

Some applications need to measure the X, Y, Z coordinates that describe the physical shape of an object such as a plastic model or a person's face. This measurement can be accomplished by moving The Bird's sensor over the object and recording the X, Y, Z positional outputs. Because of the sensor's size it is sometimes more convenient to mount The Bird's sensor onto a pencil or pen or some other type of device with a pointed tip (generically called a stylus) and then trace the object with the stylus tip to record its shape. Since the positional outputs of The Bird are with respect to the center of the sensor, one needs to find the corresponding X, Y, Z coordinates at the tip of the stylus. This translation of coordinates is easily accomplished with the application of some elementary trigonometry given the POSITION/MATRIX outputs and the X, Y, Z offset distances from The Bird's sensor center to the tip of the attached stylus.

Notation: X_B, Y_B, Z_B are the X, Y, Z position outputs from The Bird, that is, the location of the sensor's center with respect to the transmitter's center.

X_O, Y_O, Z_O are the offset distances from the sensor's center to the tip of the stylus.

X_S, Y_S, Z_S are the coordinates of the stylus's tip with respect to the transmitter's center.

$M(i, j)$ are the elements of the rotation matrix returned to the user when he requests POSITION/MATRIX outputs. Definition of the individual matrix elements can be found in the User's manual under the heading MATRIX.

Math: The stylus coordinates can be computed from the following:

$$X_S = X_B + X_O * M(1,1) + Y_O * M(2,1) + Z_O * M(3,1)$$

$$Y_S = Y_B + X_O * M(1,2) + Y_O * M(2,2) + Z_O * M(3,2)$$

$$Z_S = Z_B + X_O * M(1,3) + Y_O * M(2,3) + Z_O * M(3,3)$$

Application Note #2

Convert Bird Outputs to a Graphics Modeling Matrix

Purpose: Build the 12 elements of a standard computer graphics modeling matrix, $MM(i, j)$, given the 9 matrix output elements from The Bird, $MB(i, j)$, and The Bird's X, Y, Z position outputs X_{pos} , Y_{pos} , and Z_{pos} .

The standard computer graphics XYZ coordinate system is: positive X axis points to the right, positive Y axis points up, and positive Z points towards you.

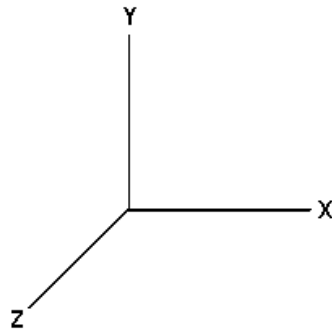

Standard Graphic Mode

The Bird's XYZ coordinate system is, when the transmitter is between you and the graphics screen and the transmitter's power cord extends in the direction toward the screen: positive X axis points out of the screen, positive Y axis points to the left, positive Z axis points down.

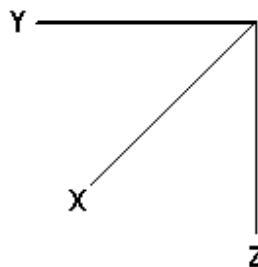

Ascension's Graphic Mode

To have the screen image follow the rotations and translations of The Bird's sensor with movement of the sensor toward the screen causing the image to move toward the front of the graphics screen, the following transformations from Bird coordinates to modeling matrix elements are required:

$$MM(1,1) = MB(2,2)$$

$$MM(1,2) = MB(2,3)$$

$$MM(1,3) = - MB(2,1)$$

$$MM(1,4) = 0.$$

$$MM(2,1) = MB(3,2)$$

$$MM(2,2) = MB(3,3)$$

$$MM(2,3) = - MB(3,1)$$

$$MM(2,4) = 0.$$

$$MM(3,1) = - MB(1,2)$$

$$MM(3,2) = - MB(1,3)$$

$$MM(3,3) = MB(1,1)$$

$$MM(3,4) = 0.$$

$$MM(4,1) = - Ypos$$

$$MM(4,2) = - Zpos$$

$$MM(4,3) = Xpos$$

$$MM(4,4) = 1.0$$

Application Note #3

Flock Stand-alone Power Supply

The Stand-alone power supply from Ascension has a safety feature which causes the unit to disconnect *internally* if plugged into the electronic unit while the power is on.

This safety feature is often misdiagnosed by users as a problem with the Electronic unit. This safety feature is called a 'crow-bar' and once engaged the power supply must be disconnected from the outlet momentarily to be reset.

To prevent the crow-bar from engaging and the resulting power termination, be sure that the power supply cable is screwed firmly into the power connector of the Flock electronic unit before plugging the power supply unit into a power outlet.

Application Note #4

CRT Sync Pulse Electrical Requirements

If you need to synchronize The Bird's measurement cycle to a piece of electronics equipment and it is not practical to use the sync pulse signal pickup provided with The Bird then you can provide your own sync pulse to The Bird. The sync pulse you provide must have the following characteristics:

1. The signal should be TTL level, normally low (ground).
2. The Bird synchronizes to the rising edge of the pulse during its low to high transition.
3. Pulse width at the high level can vary from one microsecond to one millisecond.
4. Pulse width and pulse separation should be constant from one cycle to the next.
5. Pulse rep rate should be 50 to 72 Hz if using CRT SYNC type = 2 or 100 to 144 Hz if using CRT SYNC type = 1. Either of these combinations will result in a Bird measurement rate of 100 to 144 measurements/second.
6. Change the jumpers on The Bird's printed circuit card (PCB). To change the jumpers you must open up the electronics unit per the procedure detailed in Section 2.1.5 and then locate the appropriate jumpers per the printed circuit card drawing in Appendix IV. The jumper blocks can be removed and inserted vertically with a strong set of fingers. Jumper pins 1 to 2 on jumpers 9 and 15 if using a TTL input signal or jumper pins 2 to 3 on jumpers 9 and 15 if using the CRT SYNC pickup shipped with The Bird.

Application Note #5

Using Multiple Host RS485 Interfaces

A Flock of Birds can be configured with multiple host computer RS485/422 interfaces to minimize communications delay. This interconnection scheme allows a host or multiple hosts to access multiple Birds simultaneously via multiple RS485/422 ports. Three configurations are possible; 1) A single interface to gather data from all Birds, 2) Individual host RS485/422 connections to each Bird or 3) Grouped host RS485/422 connections to The Birds. Configurations 2 and 3 will require you to modify the intra-Bird FBB cables supplied with the Flock.

For hook up of a single interface to service all Birds, please refer to Sections 2 and 4. When configured with individual host RS485/422 interfaces to each Bird, the host or hosts must have 1 RS485/422 port per Bird unit. This is shown below in the figure labeled 'Individual Host RS485/422 Interfaces'. In this configuration the host's software must only use the address of Bird that the port is attached to when sending commands to the Flock. As shown in the figure, cables that interconnect units on the Fast Bird Bus must not connect the FBB HOST DATA \pm signals found on pins 6 and 7 of the FBB connectors. In addition, each Bird unit must have the FBB HOST DATA termination jumper (JPR16) installed. As in other configurations, FBB BIRD DATA termination (JPR14) must be installed on the end units of the FBB.

The grouped configuration allows a host with multiple RS485/422 ports to attach each port to a group of Birds. Each separate group can be communicated with simultaneously over its own port. This is shown below in the figure labeled 'Grouped RS485/422 Host Interfaces'. As shown in the figure, the host has grouped units 1 and 2 to one host RS485/422 port and grouped unit 3 to a second host RS485/422 port. The group size can be as large or as small as desired. The host software must maintain a list of Bird addresses that are attached to each port. Bird addresses must be unique, you cannot repeat the same address in another group. Cables that interconnect groups on the Fast Bird Bus must not connect the FBB HOST DATA \pm signals found on pins 6 and 7 of the FBB connectors. In addition, The Bird unit at each group's end must have the FBB HOST DATA termination jumper (JPR16) installed. As in other configurations, FBB BIRD DATA termination jumper (JPR14) must be installed on the end units of the FBB.

INDIVIDUAL HOST RS485/422 INTERFACES

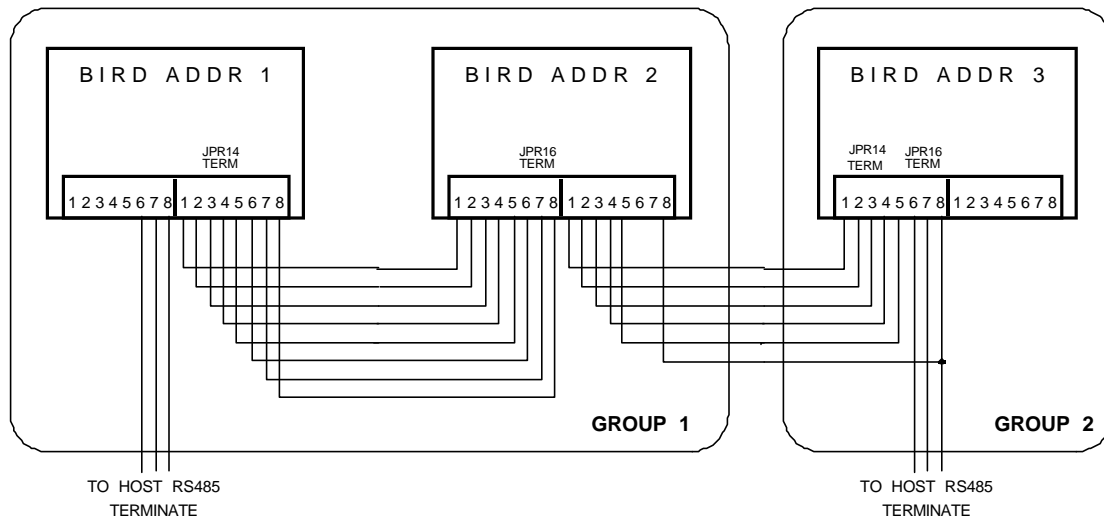
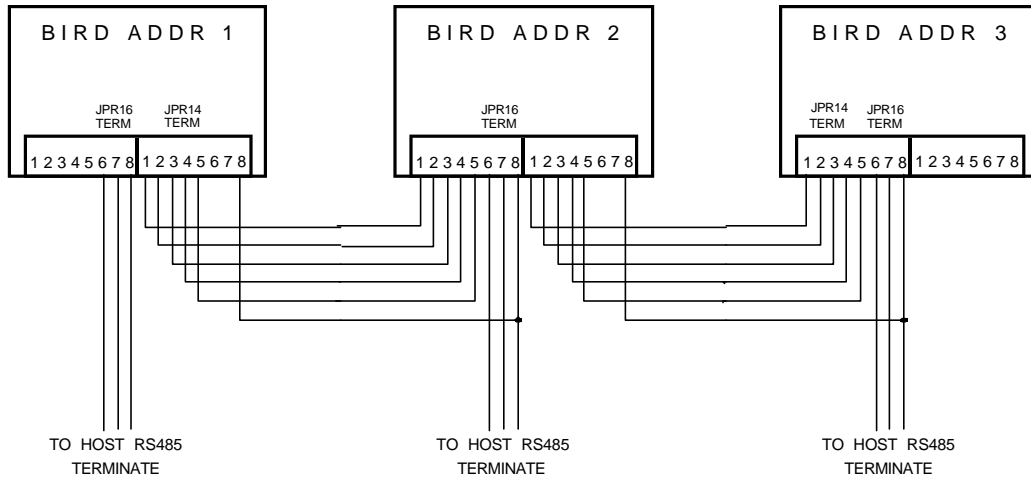

GROUPED HOST RS485/422 INTERFACES

Application Note #6

Configuring The Bird For Minimum Lag

1. Use the highest baud rate possible for collecting data from The Bird. This means that if you have a PC compatible computer then you should use 115.2K baud when using its RS232 port. If you are using The Bird's RS485 interface then you should collect data at a rate of 250K baud.
2. If you have multiple Birds in a Flock configuration then you should use individual RS232 or RS485 ports to each Bird. If you used a single port to collect data from multiple Birds then the maximum data rate is reduced by a factor of two each time you double the number of Birds on this port.
3. Use STREAM mode not POINT mode for collecting data. STREAM mode gives you data every Bird measurement cycle as soon as it has been computed. If you used POINT mode then the data request would come at some random point in The Bird's measurement cycle resulting in a random variation of up to 10 milliseconds in the 'age' of The Bird measured data.
4. Select an output format that transmits the minimum amount of data required. For example, if you only want to measure angles, then select ANGLE mode and not POSITION/ANGLE mode.
5. Unlock the outputs if you are going to be making sudden movements by setting the CHANGE VALUE, SUDDEN OUTPUT CHANGE LOCK command to zero.
6. Minimize the number of filters applied to The Bird data. To determine which filters you can remove: 1) Set The Bird's sensor at the maximum distance from the transmitter that you will be using in your application. 2) Use the CHANGE VALUE, FILTER ON/OFF STATUS command to remove one filter at a time. Observe the noise on the outputs of your measurements as you remove each filter. If the amount of noise is acceptable then leave the selected filter out. The DC filter will have the largest impact on noise and usually cannot be eliminated unless you are going to be running with the sensor close to the transmitter or you are going to filter your own data.

7. Minimize the amount of steady state filtering applied by the DC filter. Use the CHANGE VALUE, DC FILTER CONSTANT TABLE ALPHA_MIN command and increase ALPHA_MIN until the noise level is unsatisfactory. The closer the sensor is to the transmitter the larger ALPHA_MIN can be.
8. Run The Bird at a higher measurement rate. Use the CHANGE VALUE, BIRD MEASUREMENT RATE command and increase The Bird's measurement rate from its default speed of approximately 103 measurements/second. You can increase the speed up to a maximum of approximately 140 measurements/seconds. As you increase the speed you will note that the amount of noise in The Bird measurements may be higher or less than the amount of noise at the power-up default speed. The noise can increase or decrease rapidly with a speed change of just a few cycles/sec and then increase or decrease again as you continue to change the speed.
9. Reduce the amount of noise that The Bird thinks is in the local environment by using the CHANGE VALUE, DC FILTER TABLE Vm command. Set the sensor at various distances from the transmitter and reduce the Vm value for this range until the noise is unacceptable. The biggest gain in dynamic performance, other than elimination of the DC filter, comes from reducing Vm.
10. Reduce the amount of filtering during the steady state part of fast movements by using the CHANGE VALUE, DC FILTER CONSTANT TABLE ALPHA_MAX. Set ALPHA_MAX as close to 0.999 as possible. The larger alpha_max is, the less lag there will be during fast motions. But note, the larger alpha_max is, the larger the noise will be during the movement.

At Ascension when we want a 'snappy' response with good noise characteristics we use all system defaults except for the following overrides:

- a). Stream mode
- b). Sudden output change lock = 0
- c). DC filter ON, AC narrow notch filter ON, AC wide notch OFF
- d). Vm table = 2, 2, 2, 10, 10, 40, 200

Where most of the 'snap' comes from the Vm table.